



## 7.0

### RINVII ANGOLARI RL

### RIGHT ANGLE GEARBOX RL WINKELGETRIEBE

7.1	Caratteristiche	<i>Characteristics</i>	Merkmale	112
7.2	Designazione	<i>Designation</i>	Bezeichnung	113
7.3	Fattore di servizio FS	<i>Service factor FS</i>	Betriebsfactor FS	114
7.4	Dati tecnici	<i>Technical data</i>	Technische Daten	114
7.5	Carichi radiali e assiali (N)	<i>Radial and axial loads (N)</i>	Radial und axial Belastungen (N)	114
7.6	Dimensioni	<i>Dimensions</i>	Abmessungen	115

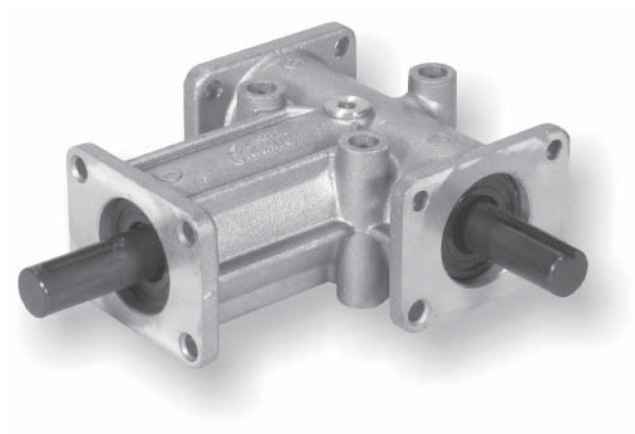



I rinvii angolari serie **RL** sono stati progettati per applicazioni industriali ove occorre trasmettere un moto rotatorio di potenza tra alberi disposti perpendicolarmente tra loro.

Possono essere a 2 o 3 uscite con rapporto di trasmissione: 1:1 o 2:1.

*The right angle gearboxes **RL** Series have been designed for industrial applications when rotary power must be transferred to the shafts perpendicularly arranged. They could have 2 or 3 output shafts and have 1:1 or 2:1 ratio.*

Die Winkelgetriebe der Serie **RL** sind für den industriellen Einsatz ausgelegt und wenn die Drehbewegung um 90° umgelenkt werden muss. Die Getriebe sind mit 2 oder 3 Wellenenden ausgeführt und können mit Untersetzungsverhältnissen von 1:1 oder 1:2 geliefert werden.

## 7.1 Caratteristiche

### Carter

Monoblocco rigido in lega d'alluminio con 5 piani di attacco e 3 possibilità di centraggio.

### Ingranaggi

Conici a dentatura spiroidale GLEASON. Sono costruiti in acciaio al Nickel-Cromo e sottoposti ad un trattamento superficiale di cementazione e tempra e successivo rodaggio. Il gioco angolare fra gli ingranaggi è regolato per garantire un ingranamento ed una silenziosità ottimali; a richiesta possono essere forniti con gioco angolare ridotto fino a 5'.

### Alberi

Sono costruiti in acciaio con una resistenza di 80 Kg/mm<sup>2</sup> e protetti superficialmente contro la corrosione.

L'attacco esterno è previsto con un trasciamamento a linguetta a norma UNI (ad eccezione della grandezza 1). Le posizioni angolari delle linguette sugli alberi entrata e uscita non hanno particolari riferimenti tra loro.

### Cuscinetti

Sono a sfere, largamente dimensionati e a gola profonda.

### Tenute lubrificante interno

Con anelli di tenuta su tutti i modelli. A richiesta sono disponibili anelli speciali per alte o basse temperature.

### Lubrificazione

I rinvii vengono forniti già equipaggiati di lubrificante: la grandezza 31 con grasso permanente; tutte le altre grandezze con olio.

## 7.1 Characteristics

### Housing

*Single-piece aluminium alloy casting with 5 mounting points and 3 flanges.*

### Gears

*Bevel gears GLEASON toothed are made of Nickel – Chrome steel and are submitted to a surface case - quench hardening treatment before the running in.*

*The backlash between gears ensures maximum service life and very low noise level. Back lash tolerances can be reduced to a minimum of 5' if specifically requested.*

### Shafts

*The shafts are made of steel with 80Kg/mm<sup>2</sup> resistance and surface treated against corrosion.*

*The external coupling is carried out by means of a key UNI standard (except for the size 1) . Keyways can be made at any angle, no special references between them are necessary.*

### Bearings

*Ball bearings liberally dimensioned and with deep races.*

### Oilseals

*Oilseal rings are fitted to all models. Special seal rings for high or low temperatures are available upon request.*

### Lubrication

*The right angle gearboxes are supplied complete with lubrication: the size 31 is filled with long life grease; the other sizes are filled with oil.*

## 7.1 Merkmale

### Gehäuse

Starres Getriebegehäuse aus Leichtmetall mit 5 Befestigungsflächen und 3 Zentriermöglichkeiten.

### Verzahnung

Die auf Gleason-Maschinen hergestellten Kegelräder sind aus Nickel-Chrome Stahl und wurden vor dem Einlaufen einsatzgehärtet. Das Zahnflankenspiel zwischen den Rädern ist für optimale Eingriffseigenschaften und Laufruhe ausgelegt, auf Wunsch kann das Spiel bis auf 5' reduziert werden.

### Wellen

Die aus speziell behandeltem Stahl mit einer Festigkeit von 80 kg/mm<sup>2</sup> gefertigten Wellen sind korrosiongeschützt.

Die Abtriebswelle ist mit Passfedern nach UNI – Norm versehen (mit Ausnahme der Baugröße 1). Die Passfedern können jede beliebige Winkelposition einnehmen.

### Lager

Grosszügig dimensionierte Kugellager mit tiefer Laufrille.

### Dichtungen

Alle Winkelgetriebe sind mit Dichtringen versehen. Auf Anfrage sind Sonderdichtringe für hohe bzw niedrige Temperaturen lieferbar.

### Schmierung

Die Winkelgetriebe werden mit Schmiermittel geliefert. Die Baugröße 31 ist mit Lebensdauer-Fett-Schmierung gefüllt, die anderen Größen sind mit Öl geschmiert.

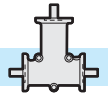

7.2 Designazione

7.2 Designation

7.2 Bezeichnung

Macchina Machine Maschine	Tipo Type Typ	Pos. alberi Shafts position Wellenposition	Rapporto rid. Ratio Unter- setzungsverhältnis	Versione Version Ausführung
<b>RL</b>	<b>32</b>	<b>AB</b>	<b>1:1</b>	<b>3FL</b>
<b>RL</b>	31 32 33 34 42	AB AC BC	1:1 2:1	3FL

Posizione alberi e sensi di rotazione

Shafts position and direction of rotation

Wellenposition und Drehrichtung

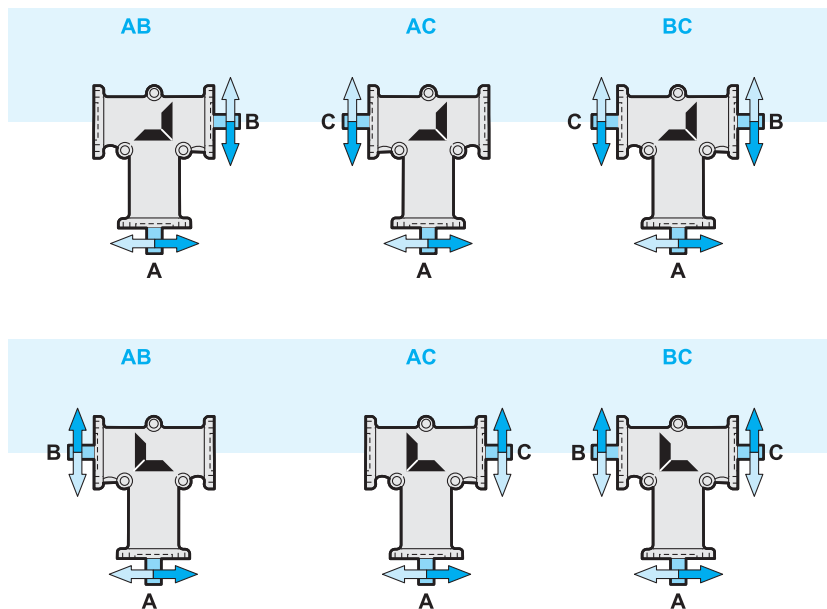

PA = albero entrata  
B = albero uscita lato corona conica  
C = albero uscita lato opposto alla corona conica

A = Input shaft  
B = Output shaft on ring bevel gear side  
C = Output shaft on opposite side to ring bevel gear

A = Antriebswelle  
B = Abtriebswelle auf Kegelmantel-seite  
C = Abtriebswelle auf der gegenüberliegenden Seite des Kegelmantels

Le figure mostrano, per ogni versione, i sensi di rotazione degli alberi.

For each version the following pictures will show the direction of rotation of the shafts

Die Abbildungen zeigen für jede Version die entsprechende Drehrichtung der Welle.

Per ogni versione, lo stesso rinvio è rappresentato in due posizioni ruotate di 180°.

The right angle gearbox is shown in two positions turned by 180°.

Für jede Version wird das gleiche Getriebe in zwei, jeweils um 180° gedrehten Positionen dargestellt.



### 7.3 Fattore di servizio FS

### 7.3 Service factor FS

### 7.3 Betriebsfactor FS

	h/d			
	3	8	12	24
<b>A</b>	0.7	0.9	1	1.3
<b>B</b>	0.9	1	1.3	1.8
<b>C</b>	1.3	1.6	1.8	2.3

**h/d**  
ore di funzionamento giornaliere  
*working hours per day*  
Tägliche Betriebszeit in Std.

**A**  
carico uniforme  
*uniform load*  
Gleichmäßiger Betrieb

**B**  
carico con urti modesti  
*load with moderate shocks*  
Mittelstarke Stöße beim Betrieb

**C**  
carico con urti  
*load with shock*  
Starke Stöße beim Betrieb

**N.B.**  
Verificare che la temperatura di esercizio non superi i valori da -20°C a +80°C.  
Nel caso del rapporto 2:1 non usare il rinvio in moltiplicazione (cioè entrando dall'albero B o C) oltre 700 giri al minuto.

**N.B.**  
*check that the operating temperature does not exceed the values -20°C / + 80°C. If you require a 2:1 ratio, do not use a speed multiplier (i.e. with inputs on shaft B or C) which operates at more than 700 rpm.*

**N.B.**  
Die Betriebstemperatur sollte nicht außerhalb des folgenden Bereichs liegen: -20°C / + 80°C.  
Falls die Getriebe als Übersetzungsgetriebe (ins Schnelle) verwendet werden sollen, ist darauf zu achten, dass die Antriebsdrehzahl an der Welle B oder C 700Upm nicht überschreiten darf.

### 7.4 Dati tecnici

### 7.4 Technical data

### 7.4 Technische Daten

n <sub>2</sub> [min <sup>-1</sup> ]	i	RL 31		RL32		RL33		RL34		RL42	
		1:1	2:1	1:1	2:1	1:1	2:1	1:1	2:1	1:1	2:1
3000	T2 [Nm]	2.0	—	7.7	—	20.2	—	33	—	5.7	—
	P1(kW)	0.63	—	2.5	—	6.5	—	11	—	1.7	—
1400	T2 [Nm]	2.4	0.9	8.6	4.2	25.2	17.9	42	29.5	8.4	6.7
	P1(kW)	0.37	0.14	1.3	0.65	3.9	2.8	6.5	4.5	1.2	0.94
1000	T2 [Nm]	2.6	1.0	9.2	4.5	27.1	19	46	33	9.8	8.0
	P1(kW)	0.29	0.11	1.0	0.50	3.0	2.1	5.1	3.6	0.98	0.80
600	T2 [Nm]	2.9	1.1	10	5	29.7	21	53	37	12.4	10.2
	P1(kW)	0.19	0.07	0.67	0.33	2.0	1.4	3.5	2.5	0.75	0.62
300	T2 [Nm]	3.4	1.3	11.6	5.6	34.7	23	63	41	16.4	13.9
	P1(kW)	0.11	0.04	0.39	0.19	1.2	0.77	2.1	1.4	0.50	0.42
100	T2 [Nm]	4.2	1.5	14.5	6.2	44	26	79	44	25.4	22
	P1(kW)	0.05	0.02	0.16	0.07	0.49	0.29	0.89	0.49	0.25	0.22
50	T2 [Nm]	4.7	1.7	16.5	6.7	50.5	27	89	46	33	25.7
	P1(kW)	0.03	0.01	0.09	0.04	0.28	0.15	0.5	0.26	0.17	0.13
Kg		0.3		1.2		3.5		5.7		2	

Simbolo Symbol Symbol	Definizione Definition Definition	Definizione Definition Definition	Definizione Definition Definition
n <sub>2</sub>	Giri uscita <i>Output revs</i>	Umdrehungen Abtrieb	
i	Rapporto <i>Ratio</i>	Untersetzung	
T <sub>2</sub>	Coppia uscita max. <i>Max. output torque</i>	Max. Abtriebsdrehzahl	
P <sub>1</sub>	Potenza entrata <i>Input power</i>	Antriebsleistung	
Kg	Massa <i>Masse</i>	Masse	

### 7.5 Carichi radiali e assiali (N)

### 7.5 Radial and axial loads (N)

### 7.5 Radiale und Axiale Belastungen (N)

	Fr	Fa
<b>RL31</b>	210	110
<b>RL32</b>	410	200
<b>RL33</b>	760	430
<b>RL34</b>	880	490

**Fr:**  
Carico radiale max. N applicato a metà della sporgenza dell'albero  
Max radial load in N applied mid of shaft extension  
Max. Radialbelastung in N bei der halben Länge der herausragenden Welle

**Fa:**  
Carico assiale max. N  
Max. axial load in N  
Axial - Belastung (max) in N

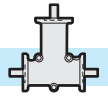

**RL 31**

**3FL**

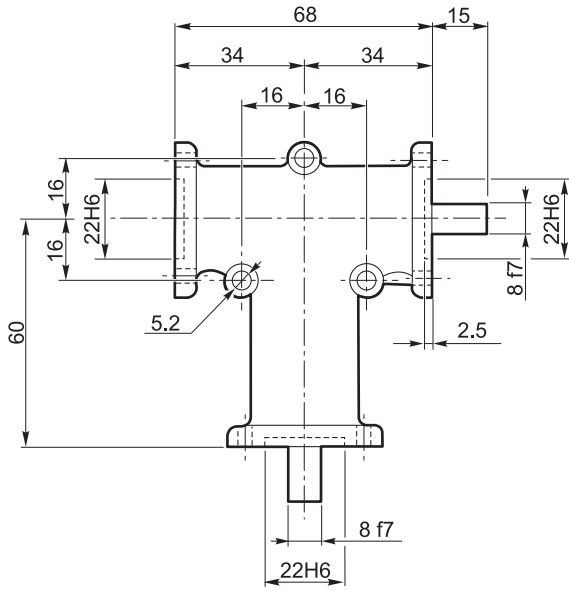

**AB**

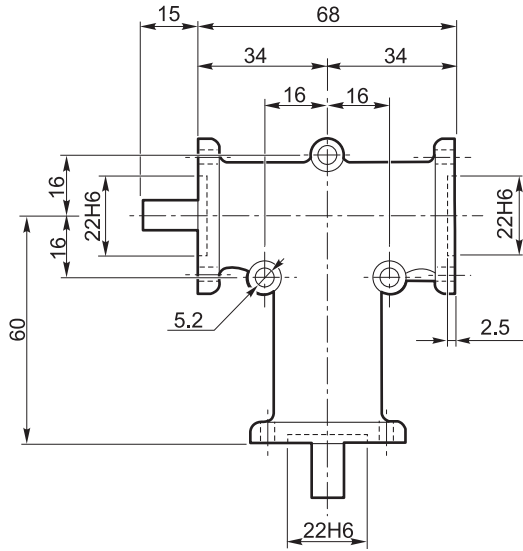

**AC**

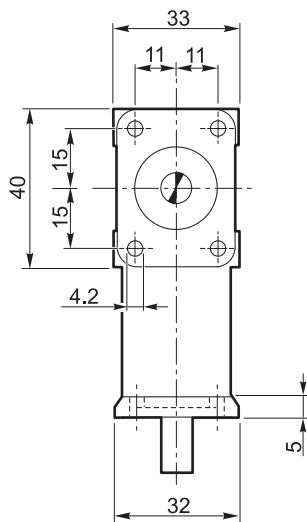

**BC**



**RL 32 - RL 33 - RL 34**

**3FL**

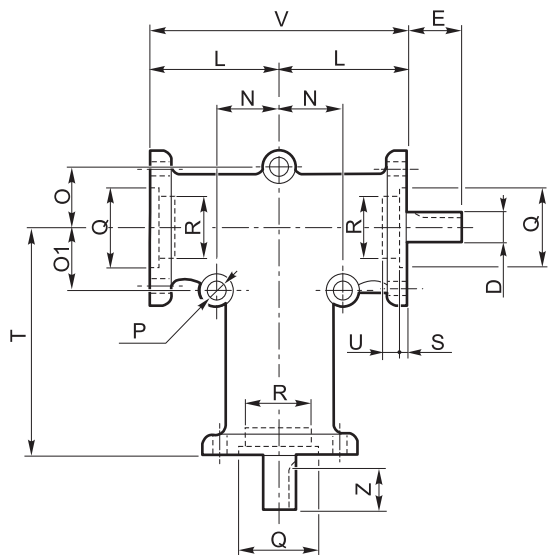

**AB**

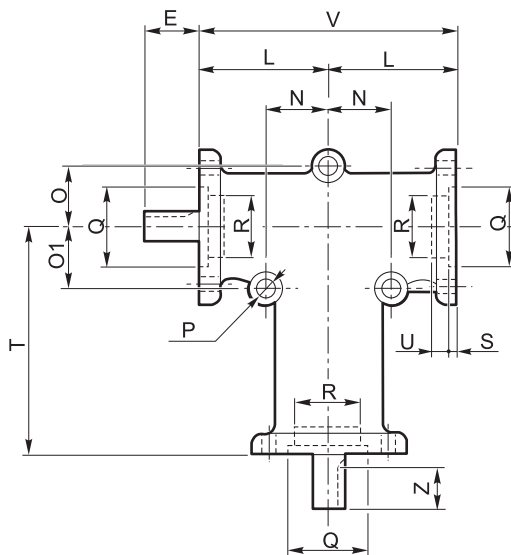

**AC**

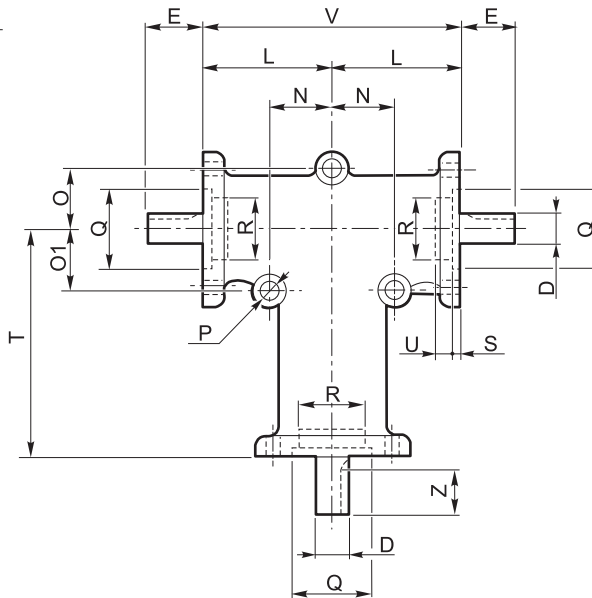
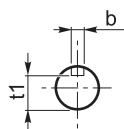
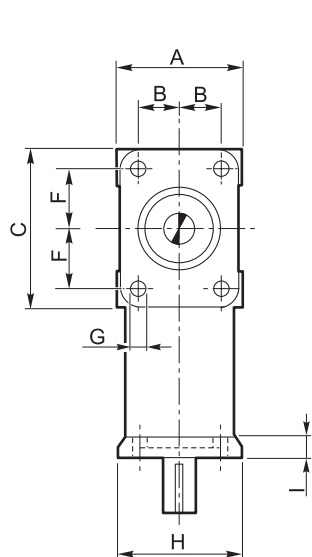

**BC**

	A	B	C	D <sub>f7</sub>	b	t <sub>1</sub>	E	F	G	H	I	L	N	O	O <sub>1</sub>	P	Q <sub>H6</sub>	R <sub>H6</sub>	S	T	U	V	Z
<b>RL 32</b>	52	18	66	15	5	12	35	26	6.2	50	7	52	24	24	24	8.3	35	-	5	90	-	104	27
<b>RL 33</b>	76	27	96	20	6	16.5	50	38	8.3	74	8	75	38	38	38	8.3	55	52	3.5	140	5	150	40
<b>RL 34</b>	100	38	98	25	8	21	70	38	10.3	98	13	80	45	45	70	10.3	65	62	3.5	150	2	160	60

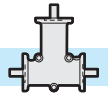

**RL 42**

**3FL**

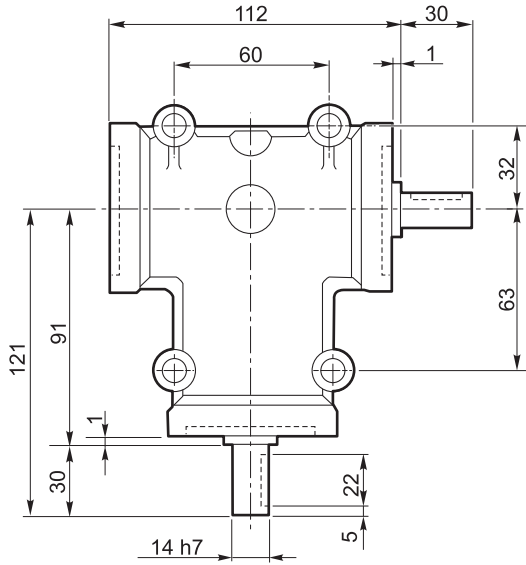

**AB**

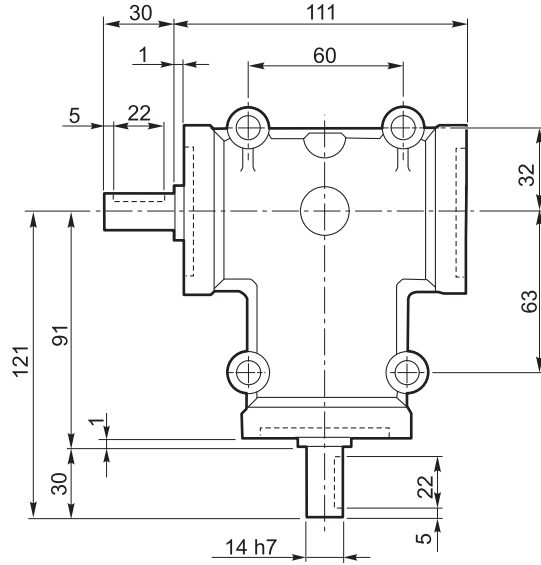

**AC**

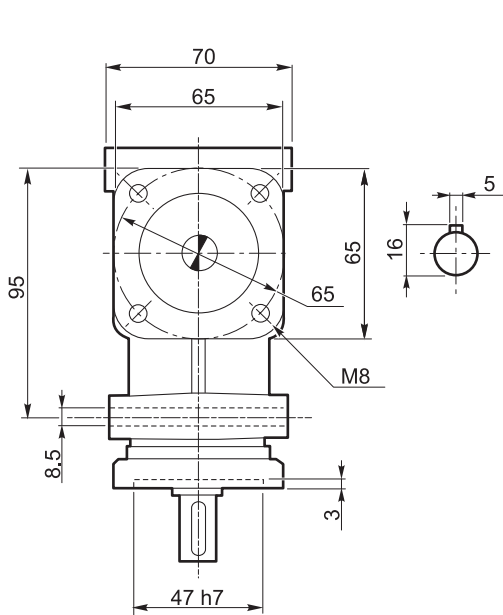

**BC**

