

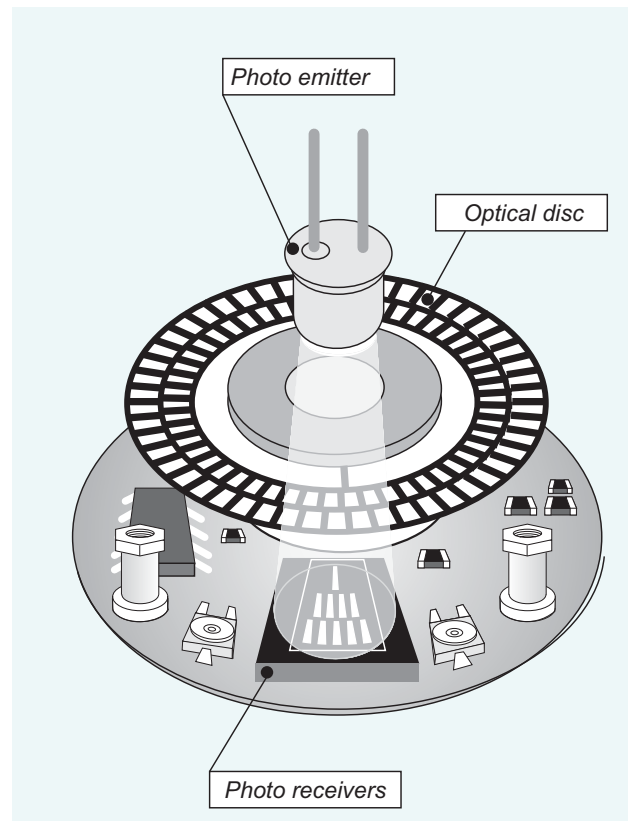

INCREMENTAL ENCODER GENERAL DESCRIPTION

Functioning Principle

The encoder is a rotational transducer to convert an angular movement into a series of electrical digital impulses. These generated impulses can be used to control angular or linear movements, if they are associated with a rack or endless screws. The electrical signals during rotation can be elaborated by numerical controls (CNC), programmable logic controls (PLC), control systems, etc. The main applications of these transducers are as follows: machine tools, working of the material, robots, retroaction systems on motors, measurement and control apparatus. In ELTRA's encoders the angular movement transduction is carried out on the photoelectric scanning principle. The reading system is based on the rotation of a radial graduated disc formed by opaque windows alternated with transparent ones. This system is all illuminated in perpendicular way by an infrared light source, so the light projects the disk image on the receivers surface, which are covered by a grating called collimator, having the same step as the disk. The receivers work transducing the light variations occurring with the disk shifting, converting them into their correspondig electrical variations.



Electrical signal raised to generate the squared impulses without any disturbances must be electronically processed. The reading system is always carried out in differential mode comparing two different signals nearly identical, but out of phase for 180 electrical degrees to increase the quality and the stability of the output signals. The reading is made on the two signals difference, eliminating the disturbances defined "shifted common way" because they are overlapped in an equal way on every type of wave.

Incremental encoders

The incremental encoder gives usually two types of squared waves that are out of phase for 90 electrical degrees, which are usually called channel A and channel B. The reading of only a channel gives the information in relation to the speed of rotation, while through the acquisition of second channel the sense of the rotation is given on the basis of the states sequence produced by the two signals. A further signal called Z or zero channel is also available, which gives the position of absolute zero on the encoder shaft. This signal is a squared impulse with the phase and the width centered on A channel.

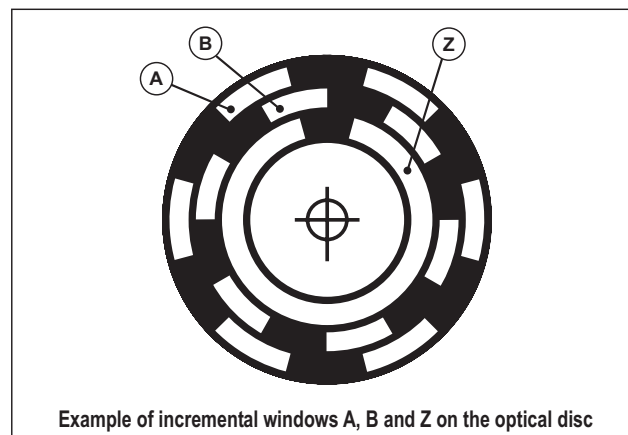

The incremental encoder precision depends from mechanical and electrical factors among which, the error in the grating division, the disc eccentricity, the bearings eccentricity, the error introduced by the reading electronics and the innaccuracy of optic. The unit of measurement, to define the encoder precision is the electrical degree, which determines the division of the impulse generated by the encoder, in fact 360 electrical degrees correspond to the mechanical rotation of the shaft which is necessary to carry out a complete cycle.

To know how many mechanical degrees corresponds to electric 360° you need to apply the following formula:

$$\text{Electrical } 360^\circ = \frac{\text{Mechanic } 360^\circ}{n^\circ \text{ pulse / turn}}$$

The error of encoder division is given from the maximum shifting shown in electrical degrees, of two consecutive surges. This error exists in any encoder and is due to the above mentioned factors.

For Eltra encoders this error is included in electrical +/- 25° Max. (in whatever condition declared) which corresponds to a shifting +/- 7% from the nominal value. Regarding the shifting between the two channels shifted by electrical 90° nominally, it differs by electrical +/- 35° max, corresponding to more or less the +/- 10%.

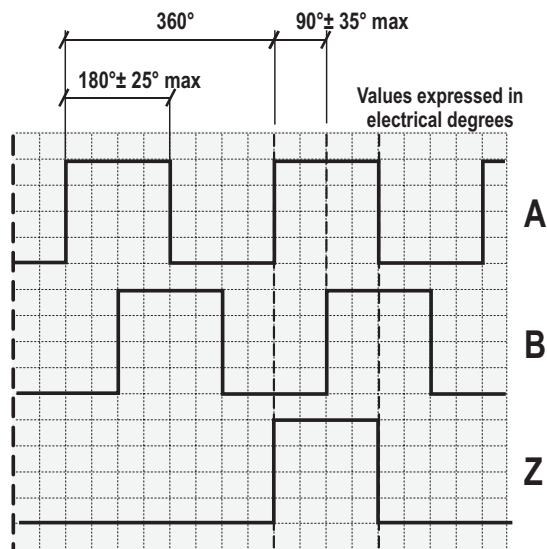

Graphic representation of the A, B and Z incremental signals .

Incremental encoder with integrated commutation phases

More than the above mentioned traditional encoders there are also other ones making part of the same incremental family, but which integrates other electrical output signals. This is the case of the incremental encoders with integrated commutation signals which are usually used as retroaction on a motor. These supplementary signals carry out the simulation function for the hall phases generally present in the commutation motors (brushless type); they are usually made with magnetic sensors. In ELTRA's encoders these commutation signals are optically generated and they are present in the form of three square waves that are shifted by electrical 120°. These signals are needed to the convertor that will pilot the motor in order to generate the correct phase voltages or the currents to supply the rotation. These commutation impulses can be repeated many times within one mechanical rotation because they depend directly to the number of poles in the connected motor, so we have phases of commutation for motors of 4, 6, or more poles.

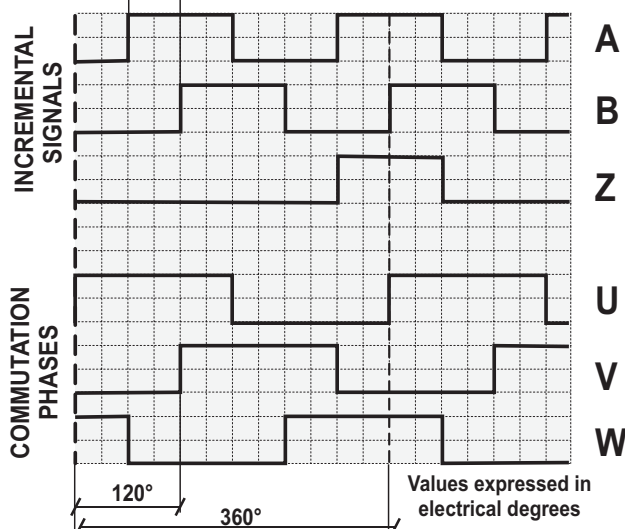

Graphic representation of A, B and Z incremental signals with commutation U, V and W.

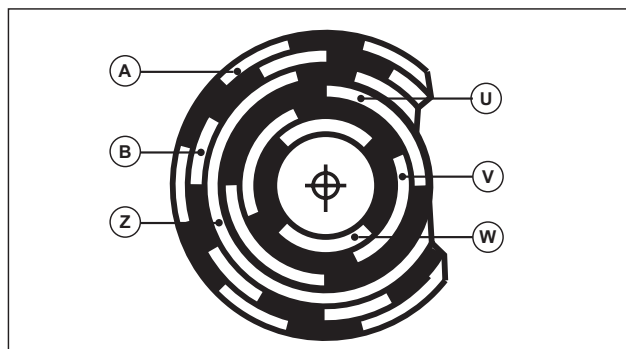

Sinusoidal Encoder

This encoder is part of the incremental family, with the main difference that the output signals are not digital but analogue of sinusoidal form. It is mainly created to satisfy the need in the motorized field as sensor of retroaction for the motor. This encoder is used when one wants to increase the dynamic performance in comparison to other traditional systems. To ensure good motor piloting performance the encoder retroaction must be able to supply a high number of impulses especially when the velocity rotation is low. The use of the traditional incremental encoder with high impulses becomes problematic from many points of view; it is also difficult transmitting and processing the digital signals when the motor rotates at high speeds (6000rpm); in this case, in fact, the band-width necessary to the servomotor to treat the signal (for example an encoder of 10.000 imp/turn), should easily surpass the MHz threshold. On the other hand, the use of analogue signals allows to limit drastically the above mentioned inconveniences and to simulate efficiently an encoder of high impulses. This happens thanks to the interpolation method of the sine and cosine analogue signals for the calculation of the rotation angle. It is easy to obtain a high multiplication of the base sinusoids by getting, for example, from 1024 sin/turn an encoder more than 100.000 imp/turn.

The band-width necessary for the reception of the signal is enough if it is little higher than 100 KHz. The output signals from the encoder are formed by two sinusoids out of phase for 90 electrical degrees, which we will call sine and cosine (2408 sin/turn MAX) and by the analogue zero signal that is centered between the two above mentioned channels. Other two sinusoidal signals are integrated with a period of 360 mechanical degrees (1sin/turn) that carry out the function of the commutation signals. The drawing below clarifies the typical configuration and the relative phase displacement. The outputs with 1 imp/turn resolution are very useful as you can get the absolute angular position in the same way as a resolver. The zero signal is also analogue and presents a form that can assimilate a part of the sinusoid. This can be easily squared to supply an impulse of reference with a variable opening angle. The fundamental data to define the precision of this encoder are the linearity of the single sinusoid (of the 2048 on turn) and the maximum deviation of any angle rotation in comparison to the real mechanical position. The max linearity error of one of these incremental sinusoid is 10%. The error referred to encoder/turn depends, obviously, to the number sin/turn of the encoder, for example the calculation of the linearity error of an 2048 sin/turn will be:

$$E.lin = 0.1 \times \frac{360 \times 60 \times 60}{2048} \approx 63''$$

The error of the deviation of the angle measured in comparison to the real one is generally produced by the above mentioned factors and is maintained within 10', taking care of the quality of the bearings and the disc centering on the shaft.

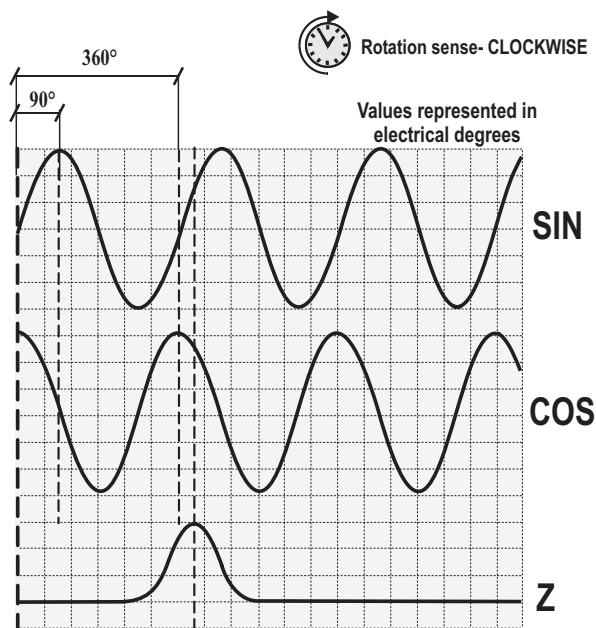

Graphic representation of the sin, cos and Z sinusoidal signals.

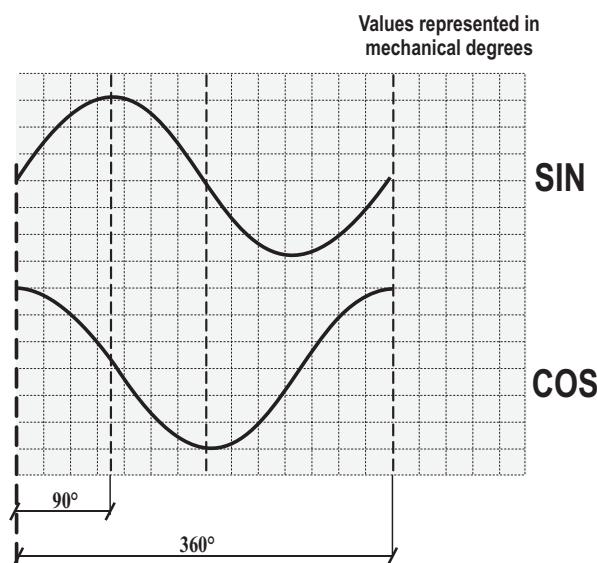

Graphic representation of the sin and cos commutation signals

SV008GB0803A





EH38A / B / D INCREMENTAL ENCODERS EH SERIES

Incremental encoder EH series

- Series of miniaturized encoders for general applications.
- Resolutions up to 1024 imp/turn
 - Different electronic configurations available with power supply up to 24 Vdc
 - Max output frequency up to 100 KHz
 - Output cable, eventual connector applied to the end of the cable
 - Different flanges available
 - Speed rotation up to 3000 rpm
 - Protection up to IP54



Ordering codes

EH 38 A 500 Z 5 N 6 X 3 P R . XXX

In case of particular Customer variant separate with a full stop

EH = incremental encoder EH series

38 = body dimension

A = mod.EH38A
B = mod.EH38B
D = mod.EH38D
Type of flanges

from **40 to 1024** imp./turn
Resolutions
N.B.: For impulse availability contact directly our offices

S = without zero impulse
Z = with zero impulse
Zero impulse

5
8 ÷ 24
Encoder power supply (Vdc)

XXX = Particular Customer variants indicated by a progressive number from 001 to 999

R = radial

P = output cable (standard length 0.5 m)

3 = 3000 max
R.P.M.

X = standard IP54
Protection

6 = ø6 mm
Shaft diameter

N = NPN
C = NPN OPEN COLLECTOR
P = PUSH PULL
L = LINE DRIVER
Electronic output configuration

N.B.: For the optionals on the output configurations see the output incremental connections card

EH38A

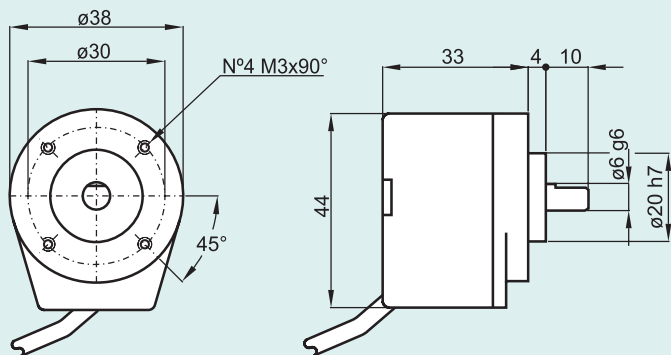

EH38B

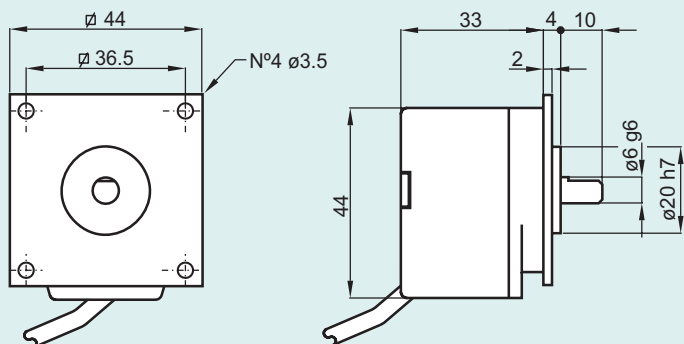

EH38D

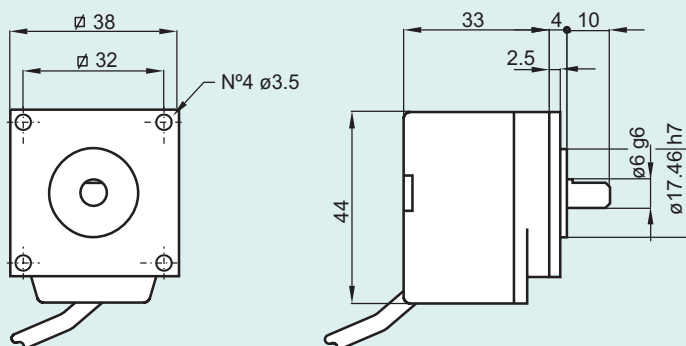

Electronic Characteristics

Resolution	From 40 to 1024 impulses / turn
Power supply	5 Vdc / 8 + 24 Vdc
Current consumption without load	50 mA bidirectional 100 mA bidirectional with zero
Max commutable current	50 mA per channel 20 mA per channel with LINE DRIVER
Electronic output configuration	NPN / NPN OPEN COLLECTOR / PUSH PULL / LINE DRIVER
Max output frequency	Max 100 KHz
Frequency calculation	$F = \frac{\text{RPM} \times \text{Resolution}}{60}$

Mechanical Characteristics

Shaft diameter (mm)	ø6 g6
Protection	IP54 - Standard
R.P.M. Max	3000 continuous
Max shaft load	5N (0.5 Kp) axial 5N (0.5 Kp) radial
Shock	50 G for 11 msec
Vibrations	10G 10 ÷ 2000 Hz
Bearings life	10 ⁹ revolutions
Bearings	n°2 ball bearings
Shaft material	Stainless steel AISI303
Body material	Aluminium UNI 5076
Square flange material	Aluminium
Cover material	Special plastic reinforced with glass fibre
Operating temperature	0° + +60°C
Storage temperature	-25° + +70°C
Weight	100 g

