



# ***DIRECT ROBOT***

*THE EFFECTIVE SOLUTION  
READY TO INSTALL AND PROGRAM*

***MECHATRONICS***

***MOTOR  
POWER***  
COMPANY

# DIRECT ROBOT

Direct Robot is a ready-to-install-and-program robot, based on direct drive standard linear modules of the series SKA Compact. Direct Robot is the effective solution for high dynamics, high precision applications with relevant load.

## RANGE OF APPLICATIONS

### MATERIAL HANDLING

- > PICK AND PLACE
- > ORDER PICKING
- > PALLETIZING
- > SORTING
- > PRODUCT STREAM DIVIDING AND GROUPING

### MATERIAL PROCESSING

- > ASSEMBLING
- > LASER CUTTING
- > PRINTING
- > DISPENSING

### TEST & MEASUREMENT

- > PROBE CARRIER
- > VISUAL INSPECTION

Direct Robot is a full embedded mechatronic device totally enclosed in its mechanical structure and provided with a motion package, including control, cabling and motion libraries. This configuration is specially designed to be integrated directly on the core of the machine or inside the manufacturing line. Direct Robot is available in two main configurations: gantry and slide bar, both featuring main axis X and Y direct drive motion.

## DIRECT ROBOT GANTRY

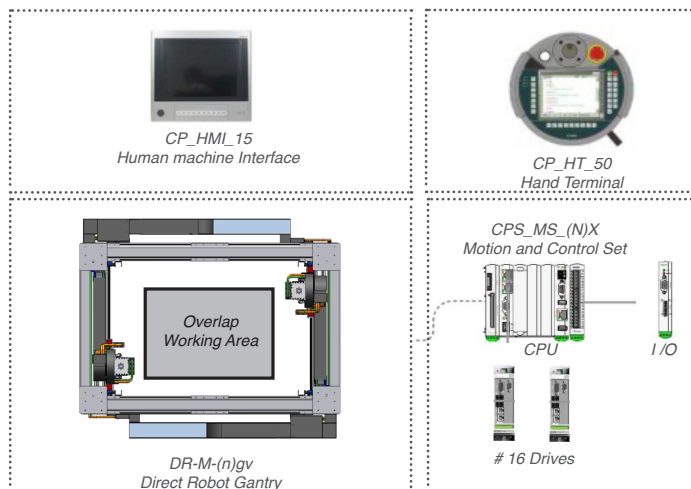

- > READY TO INSTALL GANTRY ROBOT
- > READY TO PROGRAM CONTROL/MOTION SET
- > CONTROL UP TO 16 SYNCHRONIZED AXIS
- > DOUBLE Y AXIS OPERATION
- > PAYLOAD WITHOUT VERTICAL AXIS 25KG
- > PAYLOAD WITH VERTICAL AXIS 7KG
- > OVERLAP WORKING AREA
- > SUPPLIED WITH USER CABLE

## DIRECT ROBOT SLIDEBAR

- > READY TO INSTALL SLIDE BAR ROBOT
- > X AND Y BARS ARE JOINT TOGETHER THROUGH A TECHNOPOLIMER CROSS SLIDING SYSTEM (CROSS MEMBER) WHICH THE END EFFECTOR IS APPLIED TO. THIS ALLOWS UTMOST REDUCTION OF MASSES IN MOTION AND PERMITS HIGH DYNAMICS
- > READY TO PROGRAM CONTROL/MOTION SET
- > CONTROL UP TO 16 SYNCHRONIZED AXIS
- > SUPPLIED WITH USER CABLE
- > PAYLOAD 10KG

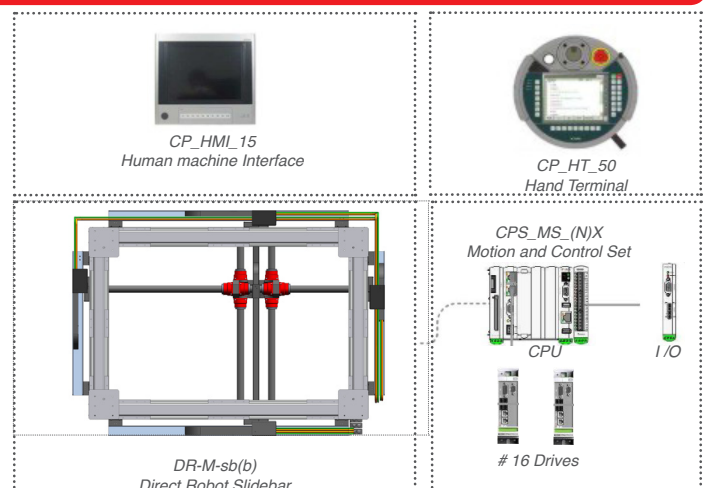

## DR-M-g

### DIRECT ROBOT GANTRY SINGLE Y

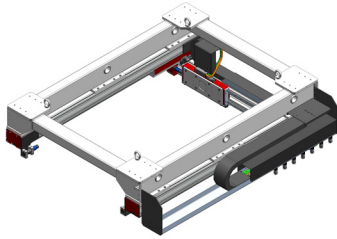

> NUMBER OF AXES	3
> MAXIMUM PAYLOAD HANGING DOWN	KG 25
> MAXIMUM DRUGGED PAYLOAD	KG 35
> MAXIMUM STROKE X AXIS	mm 4000
> MAXIMUM STROKE Y AXIS	mm 800

## DR-M-gv

### DIRECT ROBOT GANTRY SINGLE Y-Z

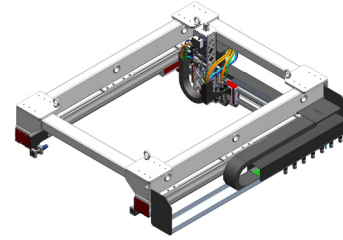

> NUMBER OF AXES	4
> MAXIMUM PAYLOAD HANGING DOWN	KG 7
> MAXIMUM DRUGGED PAYLOAD	KG 35
> MAXIMUM STROKE X AXIS	mm 4000
> MAXIMUM STROKE Y AXIS	mm 800
> MAXIMUM STROKE Z AXIS	mm 250

## DR-M-2g

### DIRECT ROBOT GANTRY DOUBLE Y

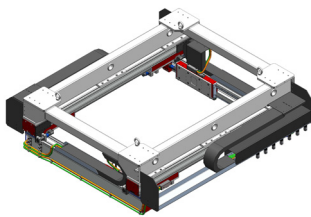

> NUMBER OF AXES	6
> MAXIMUM PAYLOAD HANGING DOWN	KG 25 + KG 25
> MAXIMUM DRUGGED PAYLOAD	KG 35 + KG 35
> MAXIMUM STROKE X AXIS	mm 4000
> MAXIMUM STROKE Y AXIS	mm 800

## DR-M-2gv

### DIRECT ROBOT GANTRY DOUBLE Y-Z

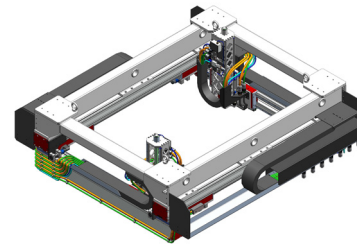

> NUMBER OF AXES	8
> MAXIMUM PAYLOAD HANGING DOWN	KG 7 + KG 7
> MAXIMUM DRUGGED PAYLOAD	KG 35 + KG 35
> MAXIMUM STROKE X AXIS	mm 4000
> MAXIMUM STROKE Y AXIS	mm 800
> MAXIMUM STROKE Z AXIS	mm 250

## DR-M-sb

### DIRECT ROBOT SLIDE BAR

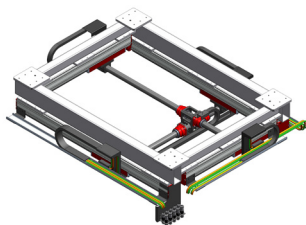

> NUMBER OF AXES	4
> MAXIMUM PAYLOAD HANGING DOWN	KG 6
> MAXIMUM DRUGGED PAYLOAD	KG 20
> MAXIMUM STROKE X AXIS	mm 1200
> MAXIMUM STROKE Y AXIS	mm 1200

## DR-M-sbb

### DIRECT ROBOT DOUBLE SLIDE BAR

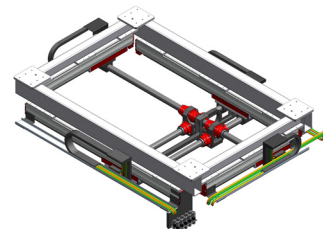

> NUMBER OF AXES	4
> MAXIMUM PAYLOAD HANGING DOWN	KG 12
> MAXIMUM DRUGGED PAYLOAD	KG 35
> MAXIMUM STROKE X AXIS	mm 1200
> MAXIMUM STROKE Y AXIS	mm 1200

> Direct Robot customized solutions according to specific needs

> Special gripper engineering

SEE IT BEFORE IT HAPPENS



## KEY FEATURES



### MD<sup>2</sup> Technology (Mechatronic Direct Drive)

Direct Robot is based on Direct Drive Technology. Mechatronic Direct Drive features real integration of mechanics, electronics, direct drive, control and motion software. The main axis are based on direct drive and are operated through robotic libraries properly set up to exploit the best of the SKA Compact axis performances, by providing a smooth and high dynamic motion.

### Ready to install module

Gantry and Slide bar modules are set up and installed on appropriate frame to allow trouble-free shipment and installation on field. Dynamic laying and static laying cables are interfaced through a connector set (IP65) fitted on the frame; this makes cables replacement and maintenance trouble-free.

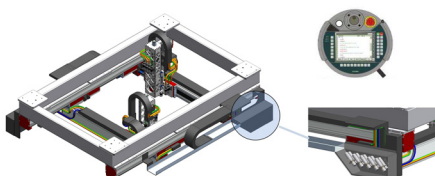

**Hand terminal** allows the user to make a fast configuration and movement of the robot axes. The robot configuration will be interfaced later with PLC layer to complete the whole application.

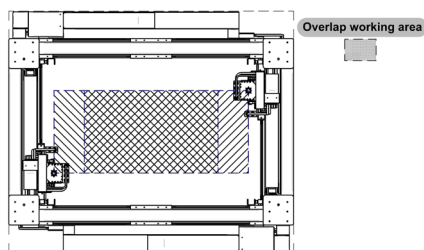

### Overlap working area

On “2g” and “2gv” version, end effectors and/or Z axis share the same working area in independent mode to increase throughput still inside a reduced footprint. The motion control set CP-MS-(n)x features inside existing libraries the management of overlapping areas.

### Sliding bar architecture

This architecture conceived as parallel kinematic chain, allows main X-Y axis to move directly the payload through the slide bar. It is possible to fit on the sliding assembly any gripper or Z axis. This configuration suits particularly the motion of high payloads in working areas up to 1200x1200mm, with repeatability of 0,5mm.

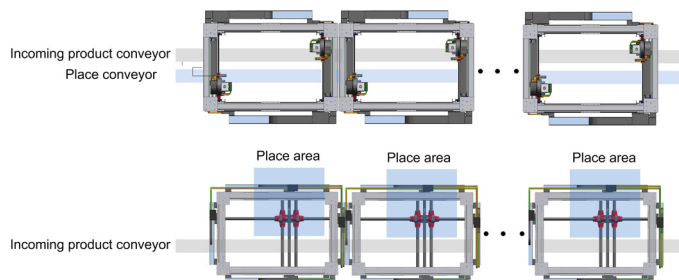
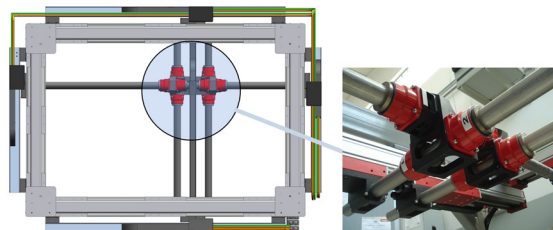

### Modularity

Both Direct Robot versions, Gantry and Sliding Bar, are arranged for modular combination either mechanically then on motion control architecture. Matrix and serial modularity.

## Performance

### > Gantry reference performances

Model: DR-M-2gv, axis X-Y-Z, nominal load 6,5 kg  
 Path: X=600mm Y=400mm Z=100mm  
 50 cycles/minute

### >> Conveyor tracking performance

Conveyor speed: 1200mm/s Repeatability: 0,2mm

### > Slide bar reference performances

Model: DR-M-sbb, axis X-Y, nominal hanging load 35 kg  
 Path: X=60mm Y=60mm  
 222 cycles/minute

### >> Conveyor tracking performance

Conveyor speed: 615mm/s Repeatability: 0,5mm

Remark: these specifications are measured on real application. Data might change depending on specific application conditions.



# CONTROL ARCHITECTURE

## MOTION CONTROL SET

- > CPU ATOM 1,1GHZ
- > 4ms CYCLE TIME
- > 8 D/I/O (EXPANDIBLE)
- > DRIVES AND CABLES SET ACCORDING TO DIRECT ROBOT CONFIGURATION EXPANDIBLE UP TO 16 AXES
- > INTERFACE: ETHERNET TCP/IP
- > SUPPORTED FILED BUS
  - >> SERCOS III
  - >> CAN OPEN
  - >> PROFIBUS
- > ROBOTIC FUNCTION LIBRARY



- >> STANDARD IEC 61131-3
- >> STRUCTURED TEXT
- >> SEQUENTIAL FUNCTION CHART (SFC)
- >> FUNCTIONAL BLOCK DIAGRAM (FBD)
- >> LADDER DIAGRAM (LD)
- >> INSTRUCTION LIST

## HUMAN MACHINE INTERFACE

- > FLAT FRONT DESIGN, 256.000 COLORS
- > RUGGED TOUCH SCREENS, HIGH BRIGHTNESS
- > 15" XGA
- > 10 FUNCTION KEYS WITH LEDS
- > TOOL LESS MOUNTING

## HAND TERMINAL

- > ERGONOMIC HANDHELD TERMINAL
- > INTUITIVE TOUCH OPERATION
- > 7" TOUCH SCREEN
- > 2 CONFIGURABLE HARD BUTTOM
- > REMOTE EMERGENCY AND KEY SWITCH INTEGRATED
- > INTEGRATED DEVELOPEMENT ENVIRONMENT FOR ROBOT FUNCTIONS

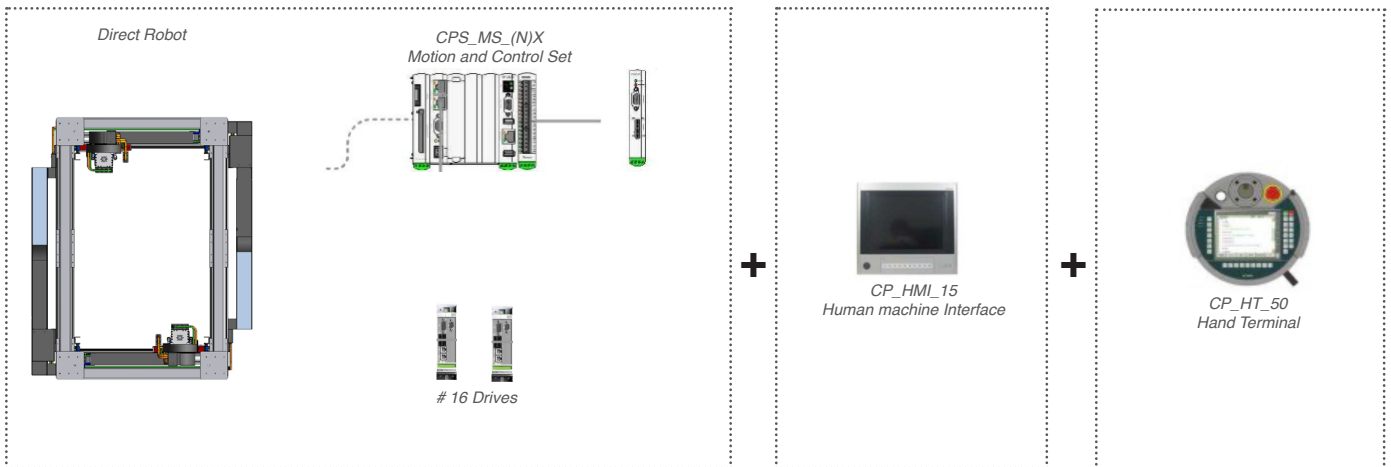

The motion control architecture is based on Core Pro environment; development environment has two main layers: PLC and Robotic. The hand terminal device allows to use at once robotic functions for fast and direct configuration of the motion part of the application. The PLC layer allows the configuration of the automation and interface part of the application.

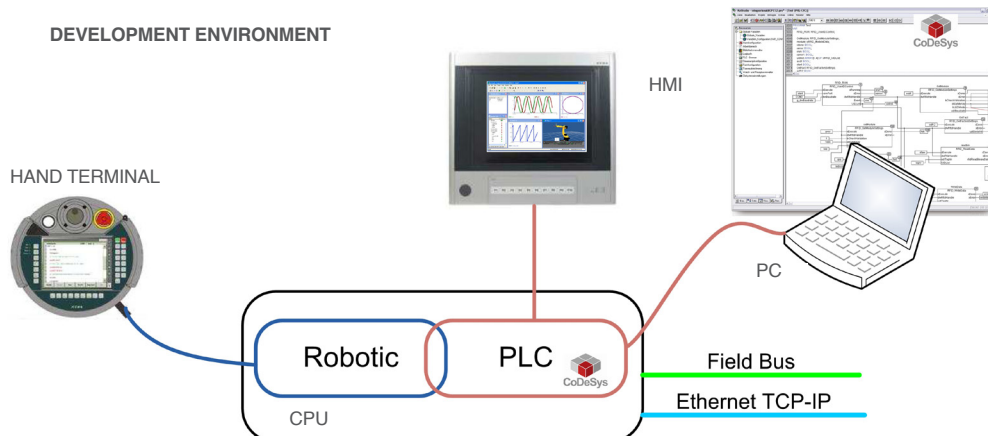

SEE IT BEFORE IT HAPPENS

# HOW TO ORDER

DR	M									
Direct Robot Model	Size	Type	X Stroke	Y Stroke	Z Axis	Z Stroke	Motion Control Set	Cables Length	HMI	Hand Terminal
					00: no axis R0: clamped base moving tablescrew	250mm	0: no MCS 1: with MCS		0: no HMI 1: with HMI	0: no HT 1: with HT
		1	2	3			4	5	6	7

- Choose the DIRECT ROBOT unit architecture

  - g: gantry single y
  - gv: gantry single y-z
  - 2g: gantry double y
  - 2gv: gantry double y-z
  - sb: slide bar
  - sbb: double slide bar
- Select the X axis stroke. Enter from 1000 to 4000mm.  
X stroke increases by 200 mm
- Select the Y axis stroke. Enter 600 or 800 mm.
- Motion Control Set.  
> 00: no MCS  
> 1: with MCS, model CP\_MS\_(n)X

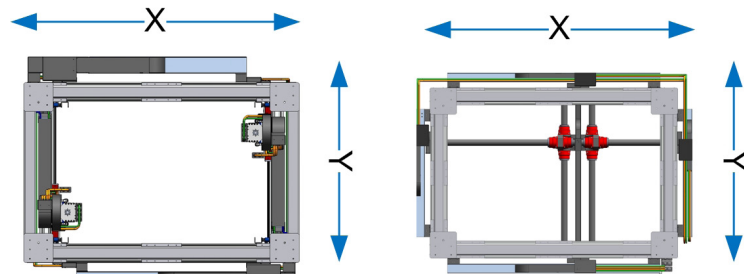

- Cable length. Select the length of Direct Robot cable connecting the robot and the motion set CP\_MS\_(n)x

  - > 00: no cable
  - > 04: 4 meters (standard)
  - > 06: 6 meters
  - > 10: 10 meters

Fieldbus and Ethernet cables are not included  
User static laying and dynamic laying cables must be ordered separately
- HMI: the human machine interface is a motion set option  
> 00: no HMI  
> 1: with HMI
- HT: the handle programming terminal is motion set option  
> 00: no HT  
> 1: with HT

**Direct Robot module** includes: X,Y (Z) axes installed and calibrated on the mechanical frame, dynamic laying cables.

**Motion Control Set** includes: Core Pro CPU, number of drives according to the Direct Robot model, 8 D I/O module, power filter.

## APPLICATION EXAMPLES

### UNSCRAMBLING

Direct Robot is applied as unscrambling function for symmetrical and asymmetrical bottles (h:100-350mm)

#### Feature:

- >> Production up to 3000 ppm
- >> Fast size change through software
- >> Vision system
- >> Modularity
- >> Electrical actuators
- >> Reduced maintenance
- >> Small foot print
- >> Working versatility
- >> X axis maximum acceleration: 20 m/s<sup>2</sup>
- >> Y axis maximum acceleration: 30 m/s<sup>2</sup>
- >> Z axis nominal force: 950N @ 1.2 m/s



#### Strengths:

Performance, modularity and exceptional high flexibility give to Direct Robot all features to be the most advantageous choice to fulfill the application requirements of unscrambling systems.

- >> A special gripper has been specifically realized for the unscrambling system
- >> Smart actuator with 2 axes for the contemporary handling of each end effector
- >> Brushless electrical actuators (Tetra Compact)
- >> Synchronization with vision system for product orientation
- >> Stand up function and bottling rotation for the positioning of all products in all possible configurations, without the using of particular pre-orientation systems

#### Absolute Z axis:

- >> Worm screw vertical axis
- >> Integrated brake
- >> Brushless electrical actuators (Tetra Compact)
- >> Absolute encoder feedback

### GLASS PROCESSING

Direct Robot is applied as gantry single Y configuration in flat glass cutting machines.

#### Feature:

- >> Fast size change
- >> Modularity
- >> Reduced maintenance
- >> High working speed
- >> X1, X2, Y axes speed: 3 m/s
- >> X1, X2 axes acceleration: 0,7 g
- >> Y axis acceleration: 1,3 g
- >> X1, X2 axis stroke: 6250mm
- >> Y axis stroke: 3700mm
- >> Glass sheet dimensions: 2750 x 3700mm





## DR-M-g

**3 AXES MAXIMUM PAYLOAD 25KG**



Direct Robot Model	Size	Type	X Stroke	Y Stroke	Z Axis	Z Stroke	Motion Control	Cables Length	HMI	Hand Terminal
			from 1000 mm to 4000 mm	> 600 mm > 800 mm	00: no axis R0: clamped base moving tablescrew	250mm	Set 0: no MCS 1: with MCS	0: no cable 04: 4m (std) 06: 6m 10: 10m	0: no HMI 1: with HMI	0: no HT 1: with HT

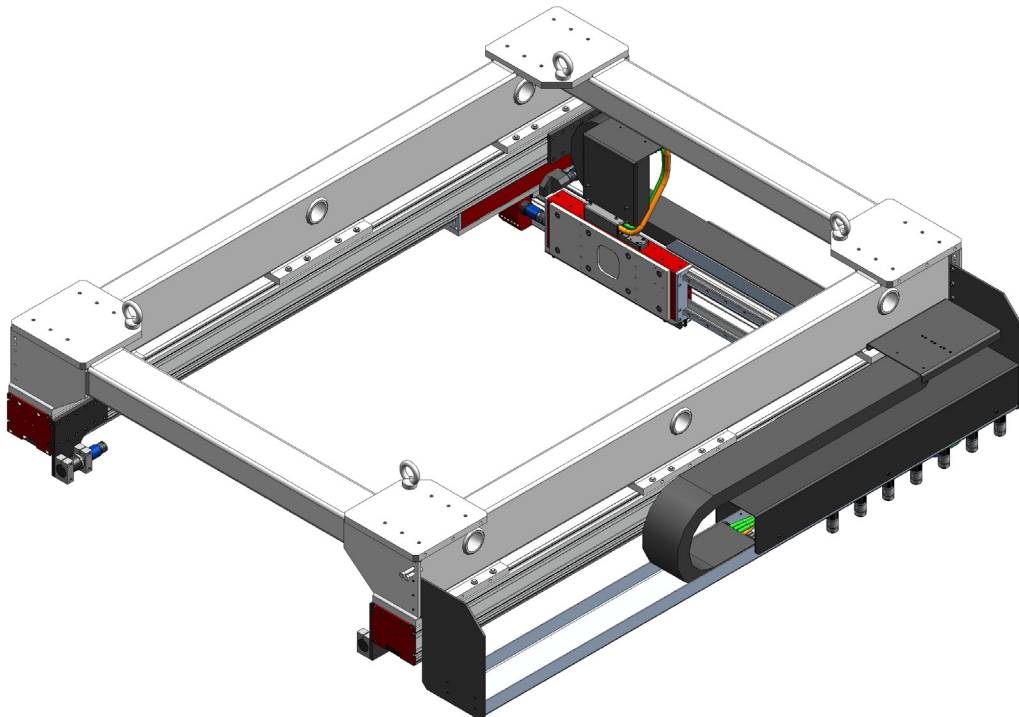

<b>X STROKE (1)</b>	1000 mm	.... ....	4000 mm
<b>Y STROKE</b>	600 mm	800 mm	

(1) X stroke increases by 200 mm

	X AXIS	Y AXIS
Position repetability (mm)	+/- 0,01	+/- 0,01
Drive system		
Sliding system	High precision ball recirculated on rail guide	
Motor	Synchronous linear	Synchronous linear
Maximum speed (m/s)	3	3
Maximum acceleration (m/s <sup>2</sup> )	35	35
Stroke range (mm)	1000 : 4000	600 : 800
Preventive maintenance	Lubrication every 15000Km	Lubrication every 15000Km

**DR-M-g**

**3 AXES MAXIMUM PAYLOAD 25KG**

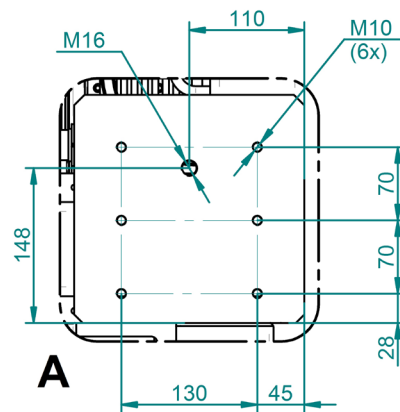
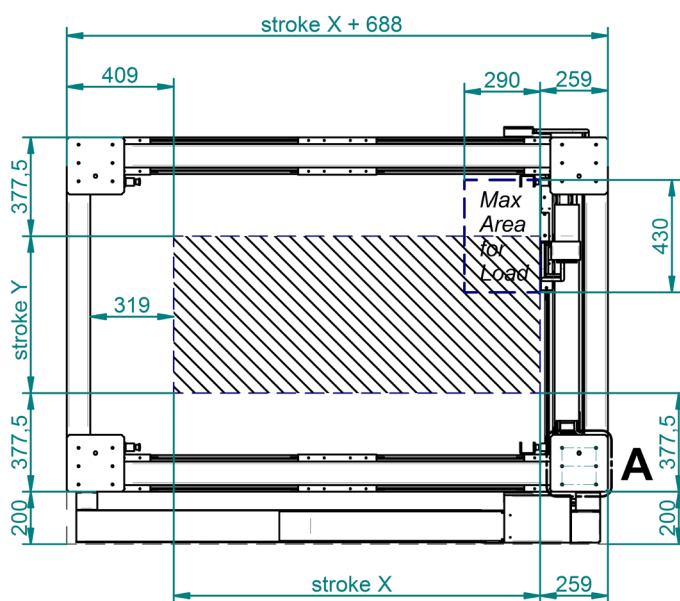
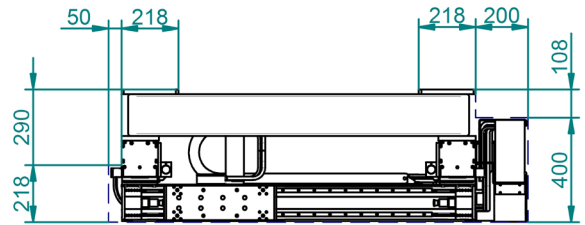
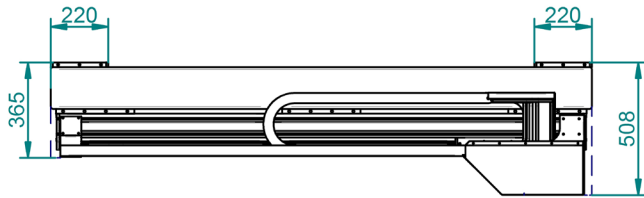

Dimensions can be modified according to application requirements

**PERFORMANCE**

Cycle/minute module**	Payload	Travel Time (ms)*			V max (m/s)			Max. acceleration (m/s <sup>2</sup> )		
		X	Y	Z	X	Y	Z	X	Y	Z
50	10 Kg	605	315		2,5	2,9		12,2	27,2	
48	18Kg	625	365		2,4	2,4		11,5	20,4	
47	25Kg	645	400		2,3	2,2		10,8	16,8	

Reference travel x= 1000mm; y= 600mm

(\*) One way travel time

(\*\*) Back and forward travel

SEE IT BEFORE IT HAPPENS

## DR-M-gv

4 AXES MAXIMUM PAYLOAD 7KG



Direct Robot Model	Size	Type	X Stroke	Y Stroke	Z Axis	Z Stroke	Motion Control Set	Cables Length	HMI	Hand Terminal
			from 1000 mm to 4000 mm	> 600 mm > 800 mm	00: no axis R0: clamped base moving tablescrew	250mm	0: no MCS 1: with MCS	0: no cable 04: 4m (std) 06: 6m 10: 10m	0: no HMI 1: with HMI	0: no HT 1: with HT

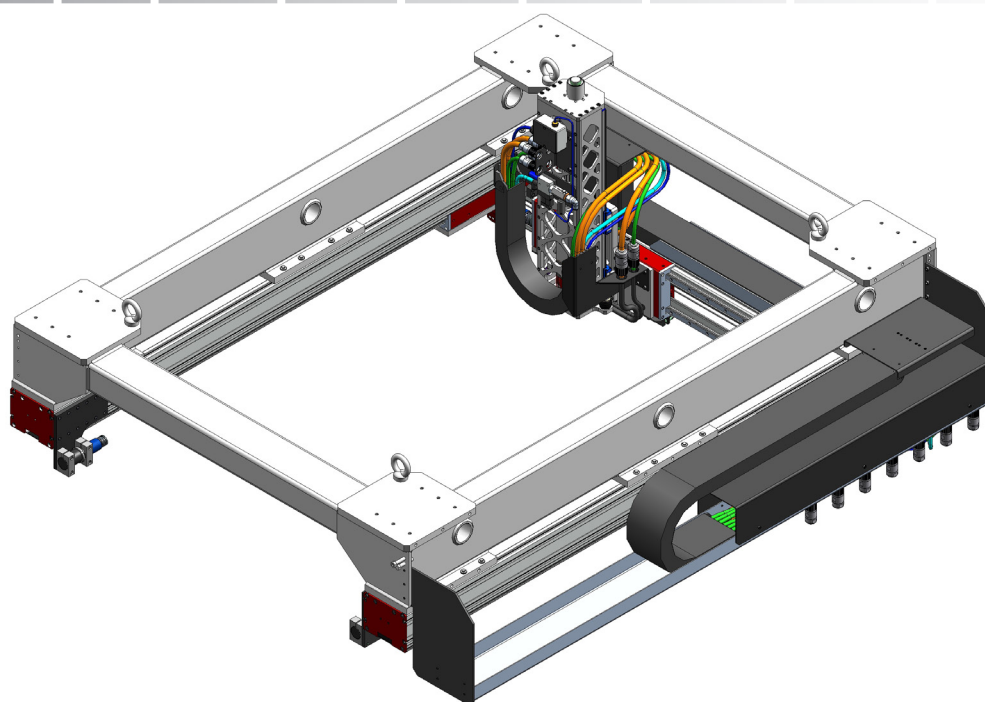

X STROKE (1)	1000 mm	....	4000 mm
Y STROKE	600 mm	800 mm	
Z STROKE	250 mm		

(1) X stroke increases by 200 mm

	X AXIS	Y AXIS	Z AXIS
Position repetability (mm)	+/- 0,01	+/- 0,01	+/- 0,01
Drive system			
Sliding system	High precision ball recirculated on rail guide		Ball screw (Class C5)
Motor	Synchronous linear	Synchronous linear	Brushless rotary
Maximum speed (m/s)	3	3	3
Maximum acceleration (m/s <sup>2</sup> )	35	35	35
Stroke range (mm)	1000 : 4000	600 : 800	250
Preventive maintenance	Lubrication every 15000Km	Lubrication every 15000Km	(*)

(\*) Z axis lubrication must be executed at any X/Y axes greasing



# DR-M-gv

**4 AXES MAXIMUM PAYLOAD 7KG**

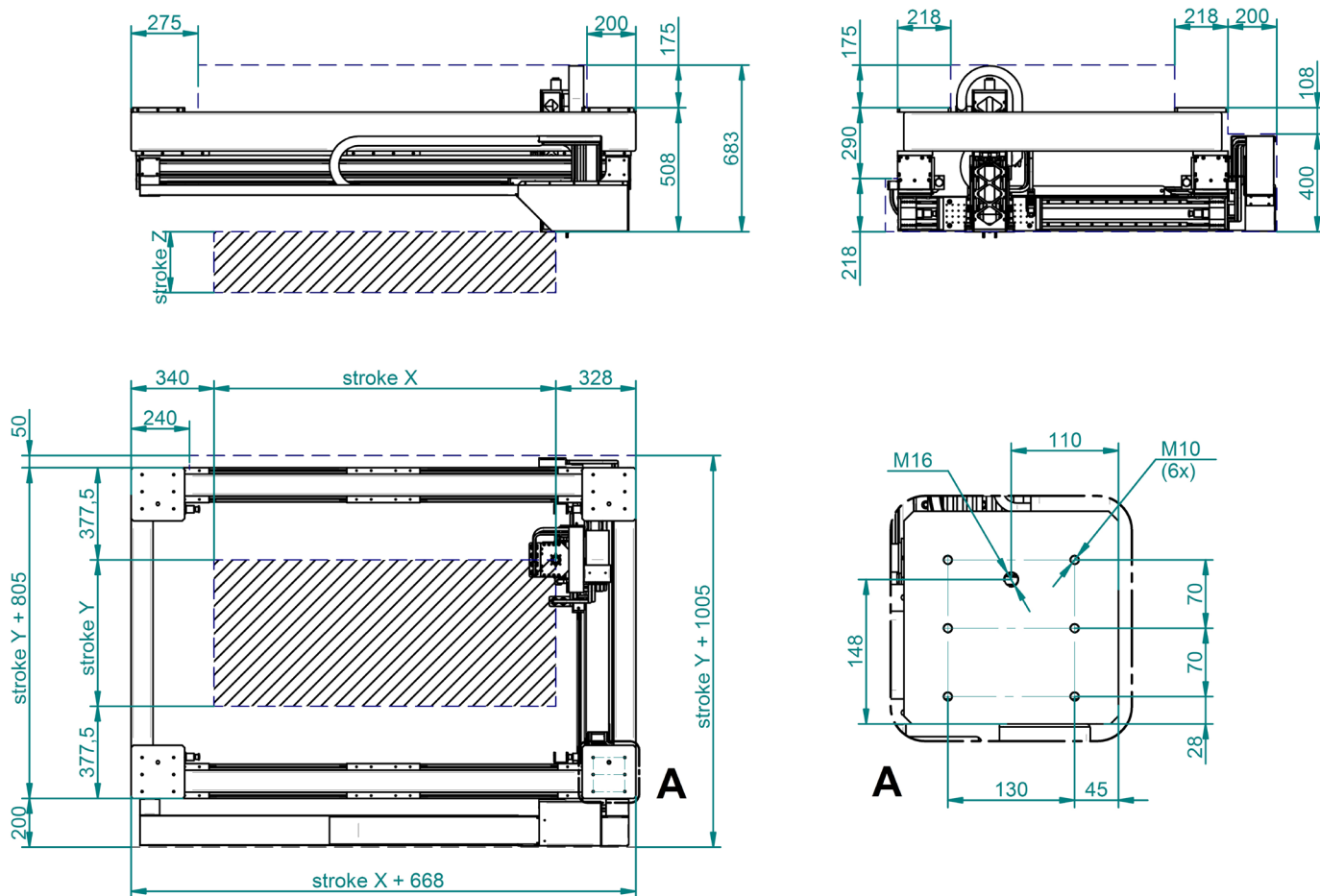

Dimensions can be modified according to application requirements

## PERFORMANCE

Cycle/minute module**	Payload	Travel Time (ms)*			V max (m/s)			Max. acceleration (m/s <sup>2</sup> )		
		X	Y	Z	X	Y	Z	X	Y	Z
46	2 Kg	655	405	140	2,3	2,2	1,0	10,4	16,4	23
45	5 Kg	660	420	140	2,2	2,1	1,0	10,3	15,3	23
45	7 Kg	665	430	140	2,2	2,1	1,0	10,2	14,5	23

Reference travel x= 1000mm; y= 600mm; z= 100mm

(\*) One way travel time

(\*\*) Back and forward travel

SEE IT BEFORE IT HAPPENS

## DR-M-2g

6 AXES MAXIMUM PAYLOAD 25KG+25KG



Direct Robot Model	Size	Type	X Stroke	Y Stroke	Z Axis	Z Stroke	Motion Control Set	Cables Length	HMI	Hand Terminal
			from 1000 mm to 4000 mm	> 600 mm > 800 mm	00: no axis R0: clamped base moving tablescrew	250mm	0: no MCS 1: with MCS	0: no cable 04: 4m (std) 06: 6m 10: 10m	0: no HMI 1: with HMI	0: no HT 1: with HT

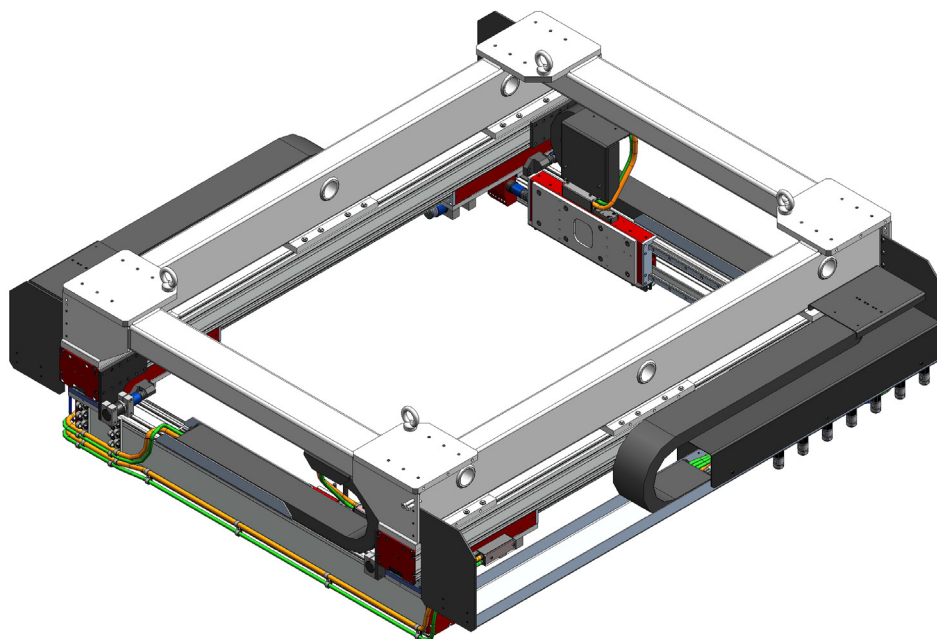

<b>X STROKE (1)</b>	1000 mm	....	4000 mm
<b>Y STROKE</b>	600 mm	800 mm	

(1) X stroke increases by 200 mm

	X AXIS	Y AXIS
Position repetability (mm)	+/- 0,01	+/- 0,01
Drive system		
Sliding system	High precision ball recirculated on rail guide	
Motor	Synchronous linear	Synchronous linear
Maximum speed (m/s)	3	3
Maximum acceleration (m/s <sup>2</sup> )	35	35
Stroke range (mm)	1000 : 4000	600 : 800
Preventive maintenance	Lubrication every 15000Km	Lubrication every 15000Km

# DR-M-2g

6 AXES MAXIMUM PAYLOAD 25KG+25KG

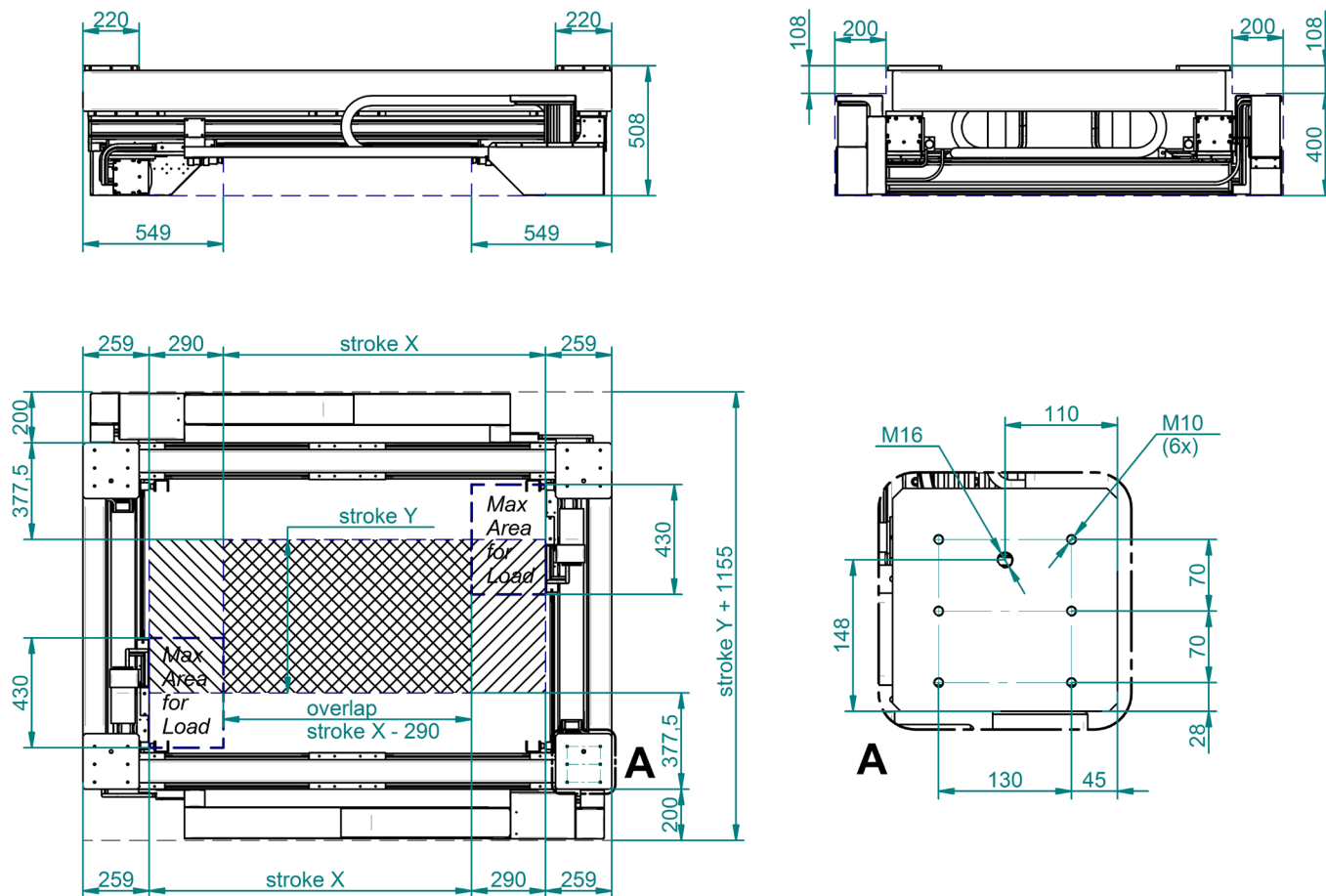

Dimensions can be modified according to application requirements

## PERFORMANCE

Cycle/minute module**	Payload	Travel Time (ms)*			V max (m/s)			Max. acceleration (m/s <sup>2</sup> )		
		X	Y	Z	X	Y	Z	X	Y	Z
2 X 50	2 X 10 Kg	605	315		2,5	2,9		12,2	27,2	
2 X 48	2 X 18Kg	625	365		2,4	2,4		11,5	20,4	
2 X 47	2 X 25Kg	645	400		2,3	2,2		10,8	16,8	

Reference travel x= 1000mm; y= 600mm

(\*) One way travel time

(\*\*) Back and forward travel

SEE IT BEFORE IT HAPPENS



## DR-M-2gv

**8 AXES MAXIMUM PAYLOAD 7KG+7KG**



Direct Robot Model	Size	Type	X Stroke	Y Stroke	Z- Axis	Z- Stroke	Motion Control Set	Cables Length	HMI	Hand Terminal
			from 1000 mm to 4000 mm	> 600 mm > 800 mm	R0: clamped base moving tablescrew 00: no axis	250mm	0: no MCS 1: with MCS	0: no cable 04: 4m (std) 06: 6m 10: 10m	0: no HMI 1: with HMI	0: no HT 1: with HT

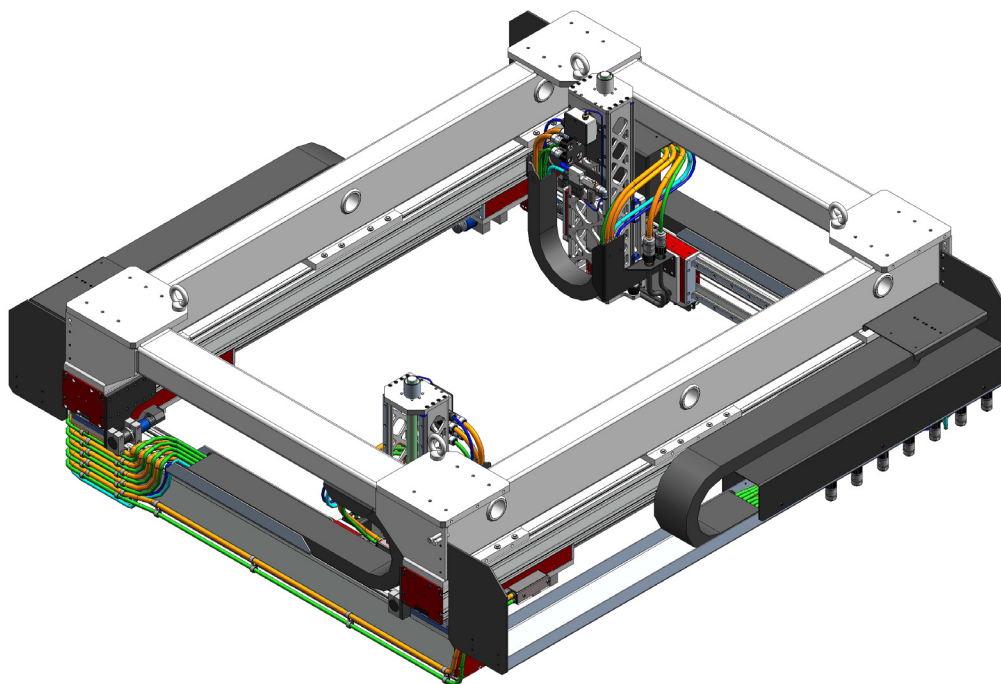

<b>X STROKE (1)</b>	1000 mm	.... ..	4000 mm
<b>Y STROKE</b>	600 mm	800 mm	
<b>Z STROKE</b>	250 mm		

(1) X stroke increases by 200 mm

	X AXIS	Y AXIS	Z AXIS
Position repetability (mm)	+/- 0,01	+/- 0,01	+/- 0,01
Drive system			
Sliding system	High precision ball recirculated on rail guide		Ball screw (Class C5)
Motor	Synchronous linear	Synchronous linear	Brushless rotary
Maximum speed (m/s)	3	3	1,5
Maximum acceleration (m/s <sup>2</sup> )	35	35	35
Stroke range (mm)	1000 : 4000	600 : 800	250
Preventive maintenance	Lubrication every 15000Km	Lubrication every 15000Km	(*)

(\*) Z axis lubrication must be executed at any X/Y axes greasing

# DR-M-2gv

**8 AXES MAXIMUM PAYLOAD 7KG+7KG**

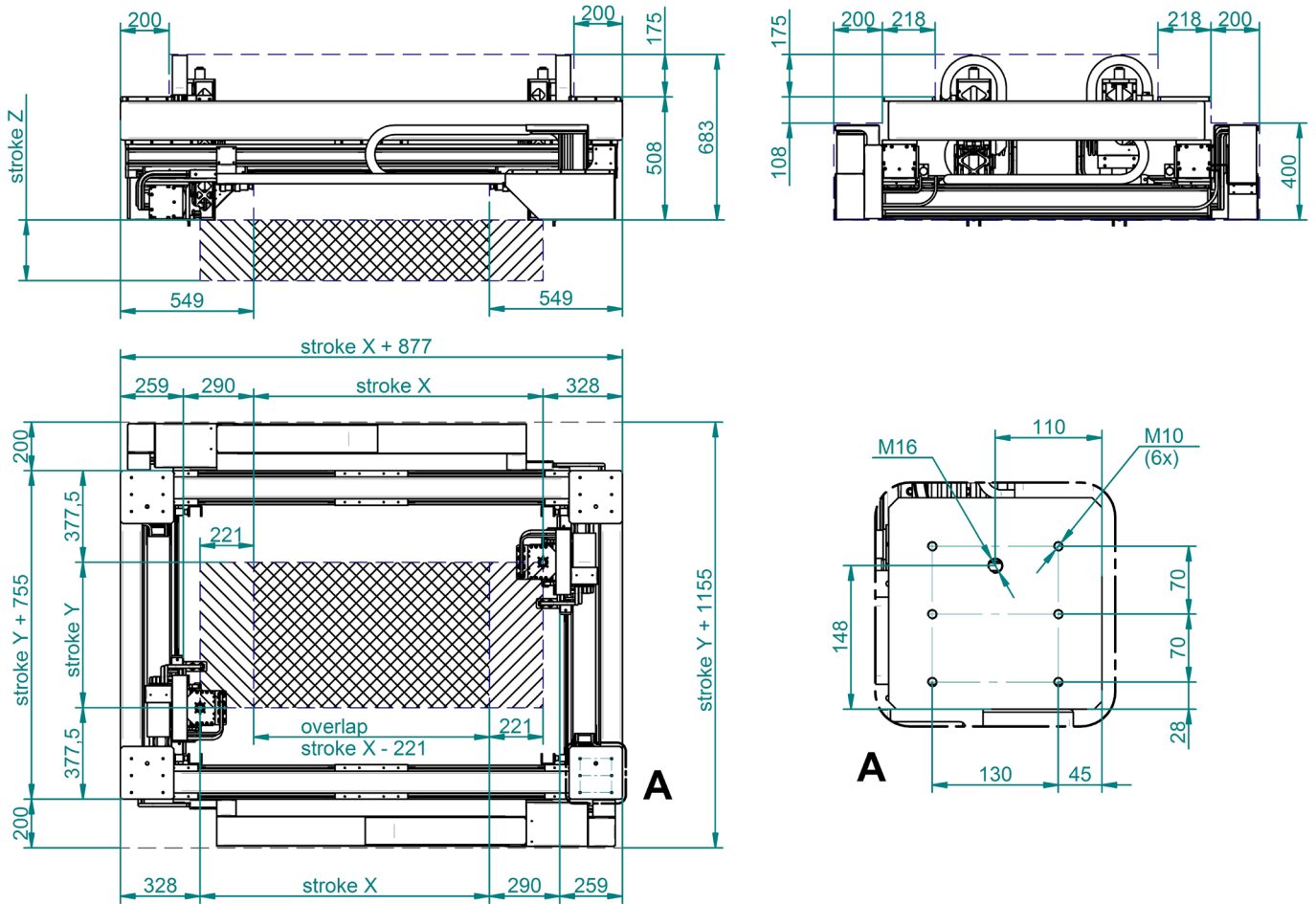

Dimensions can be modified according to application requirements

## PERFORMANCE

Cycle/minute module**	Payload	Travel Time (ms)*			V max (m/s)			Max. acceleration (m/s <sup>2</sup> )		
		X	Y	Z	X	Y	Z	X	Y	Z
2 X 46	2 X 2 Kg	655	405	140	2,3	2,2	1,0	10,4	16,4	23
2 X 45	2 X 5 Kg	660	420	140	2,2	2,1	1,0	10,3	15,3	23
2 X 45	2 X 7 Kg	665	430	140	2,2	2,1	1,0	10,2	14,5	23

Reference travel x= 1000mm; y= 600mm; z=100mm

(\*) One way travel time

(\*\*) Back and forward travel

SEE IT BEFORE IT HAPPENS

## DR-M-sb

**4 AXES MAXIMUM PAYLOAD 6KG  
PAYLOAD HANGING DOWN 20KG**

DR	M									
Direct Robot Model	Size	Type	X Stroke	Y Stroke	Z Axis	Z Stroke	Motion Control Set	Cables Length	HMI	Hand Terminal
			from 1000 mm to 4000 mm	> 600 mm > 800 mm	R0: clamped base moving tablescrew 00: no axis	250mm	0: no MCS 1: with MCS	0: no cable 04: 4m (std) 06: 6m 10: 10m	0: no HMI 1: with HMI	0: no HT 1: with HT

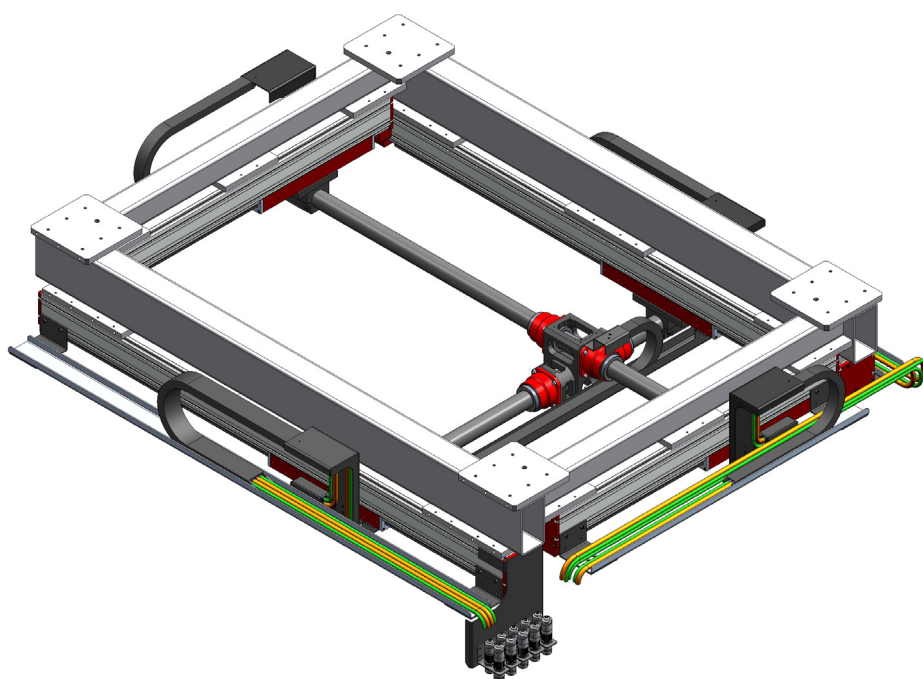

<b>X STROKE (1)</b>	600 mm	.... ..	1200 mm
<b>Y STROKE</b>	600 mm	.... ..	1200 mm

(1) X stroke increases by 200 mm

	X AXIS	Y AXIS
Position repetability (mm)	+/- 0,01	+/- 0,01
Drive system		
Sliding system	High precision ball recirculated on rail guide	
Motor	Synchronous linear	Synchronous linear
Maximum speed (m/s)	3	3
Maximum acceleration (m/s <sup>2</sup> )	40	40
Stroke range (mm)	600 : 1200	600 : 1200
Preventive maintenance	Lubrication every 15000Km	Lubrication every 15000Km



# DR-M-sb

**4 AXES MAXIMUM PAYLOAD 6KG  
PAYLOAD HANGING DOWN 20KG**

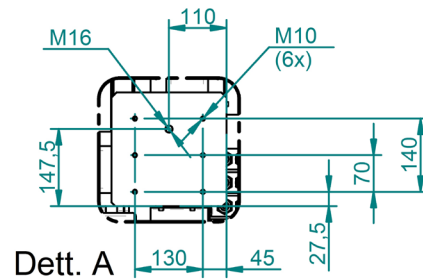
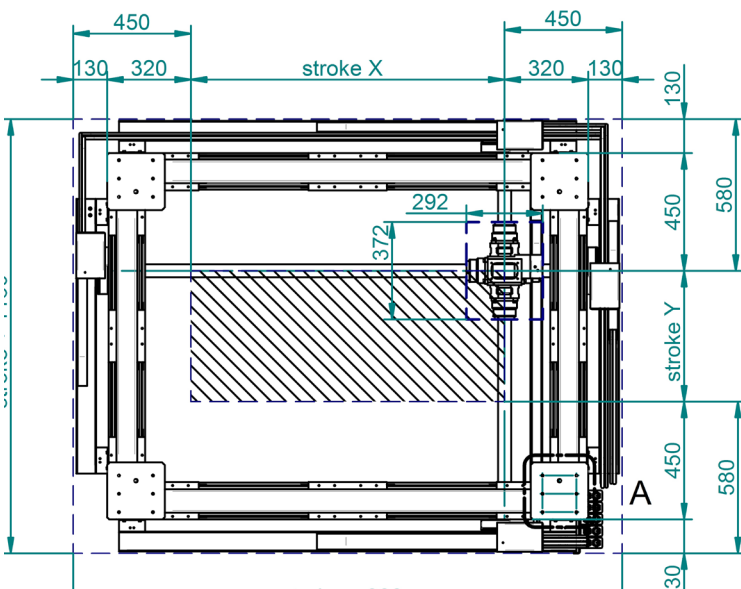
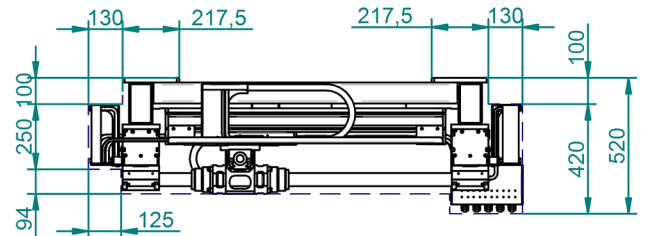
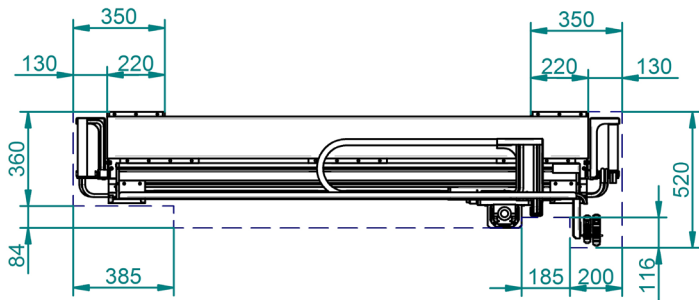

Dimensions can be modified according to application requirements

## PERFORMANCE

Cycle/minute module**	Payload	Travel Time (ms)*			V max (m/s)			Max. acceleration (m/s <sup>2</sup> )		
		X	Y	Z	X	Y	Z	X	Y	Z
66	6 Kg	455	355		3	2,5		24,6	21,4	
64	12 Kg	465	375		3	2,4		22,7	19,2	
59	20 Kg	505	390		2,9	2,3		17,6	17,8	

Reference travel x= 1000mm; y= 600mm

(\*) One way travel time

(\*\*) Back and forward travel

SEE IT BEFORE IT HAPPENS

## DR-M-sbb

**4 AXES MAXIMUM PAYLOAD 12KG**

**PAYLOAD HANGING DOWN 35KG**

DR	M	<input type="checkbox"/>	<input checked="" type="checkbox"/>	<input checked="" type="checkbox"/>	<input type="checkbox"/>	<input checked="" type="checkbox"/>	<input type="checkbox"/>	<input type="checkbox"/>	<input type="checkbox"/>	<input type="checkbox"/>
Direct Robot Model	Size	Type	X Stroke	Y Stroke	Z- Axis	Z- Stroke	Motion Control Set	Cables Length	HMI	Hand Terminal
			from 1000 mm to 4000 mm	> 600 mm > 800 mm	R0: clamped base moving table screw 00: no axis	250mm	0: no MCS 1: with MCS	0: no cable 04: 4m (std) 06: 6m 10: 10m	0: no HMI 1: with HMI	0: no HT 1: with HT

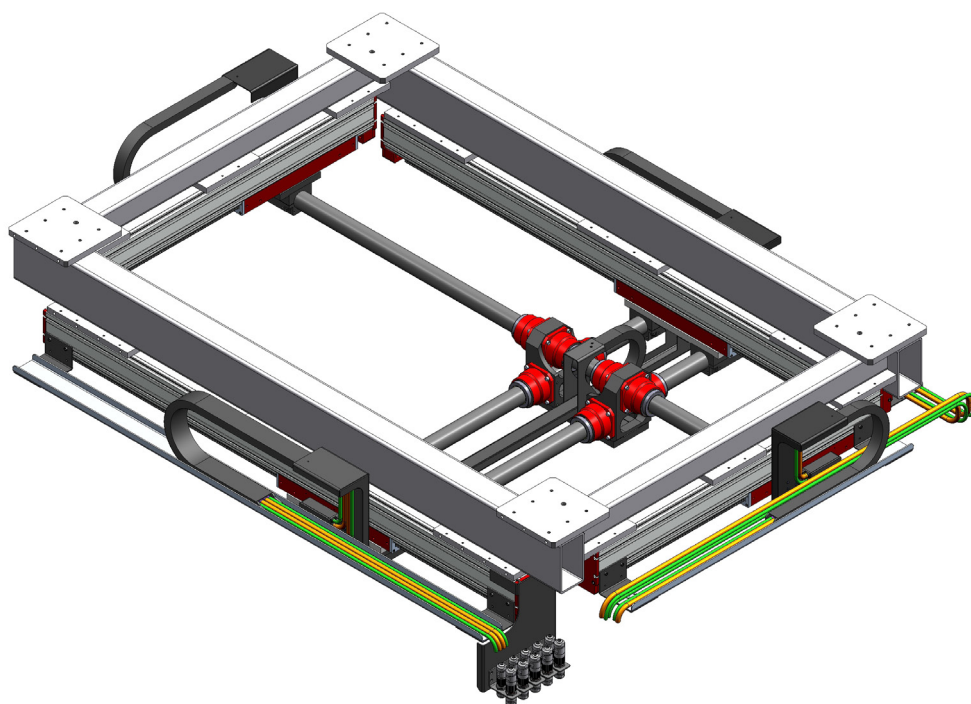

<b>X STROKE (1)</b>	600 mm	.... ..	1200 mm
<b>Y STROKE</b>	600 mm	.... ..	1200 mm

(1) X stroke increases by 200 mm

	X AXIS	Y AXIS
Position repetability (mm)	+/- 0,01	+/- 0,01
Drive system		
Sliding system	High precision ball recirculated on rail guide	
Motor	Synchronous linear	Synchronous linear
Maximum speed (m/s)	3	3
Maximum acceleration (m/s <sup>2</sup> )	40	40
Stroke range (mm)	600 : 1200	600 : 1200
Preventive maintenance	Lubrication every 15000Km	Lubrication every 15000Km

# DR-M-sbb

**4 AXES MAXIMUM PAYLOAD 12KG  
PAYLOAD HANGING DOWN 35KG**

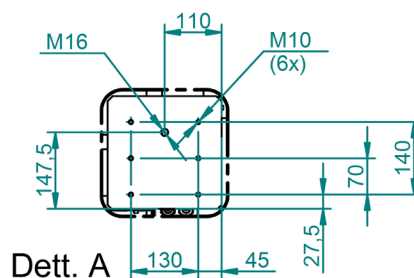
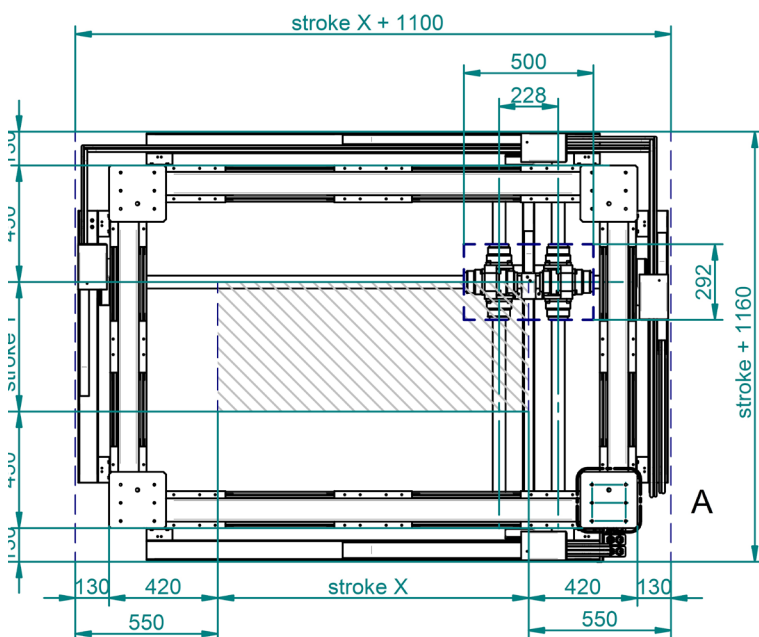
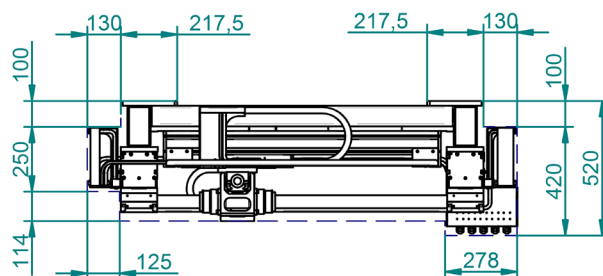
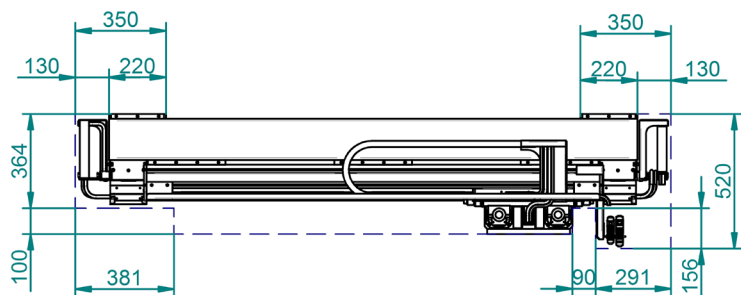

Dimensions can be modified according to application requirements

## PERFORMANCE

Cycle/minute module**	Payload	Travel Time (ms)*			V max (m/s)			Max. acceleration (m/s <sup>2</sup> )		
		X	Y	Z	X	Y	Z	X	Y	Z
55	12 Kg	550	395		3	2		14,8	17,4	
51	25 Kg	590	430		2,5	2,1		12,9	14,6	
48	35 Kg	620	450		2,4	2		11,7	13,3	

Reference travel x= 1000mm; y= 600mm

(\*) One way travel time

(\*\*) Back and forward travel

SEE IT BEFORE IT HAPPENS

motorpowerco.com

**MOTORS**

**MOTION CONTROL**

**MECHATRONICS**

**MOTOR  
POWER**  
COMPANY

**Motor Power Company s.r.l.**

Via Leonardo Da Vinci, 4  
42024 Castelnovo Sotto  
Reggio Emilia - Italia  
Tel. 0039 0522 682710  
Fax 0039 0522 683552  
info@motorpowerco.it

**Motor Power Company GmbH**

Max-Braun-Straße 8  
D-97828 Marktheidenfeld  
Germany  
Tel 0049 9391 9198905  
Fax 0049 9391 9198907  
info@motorpowerco.de

**Motor Power Company Asia Ltd.**

Room A 320, Bldg.1  
Shanghai China Electric Green  
Technology Park  
N.271 Lv Ke Rd., Pudong New Area  
201204 Shanghai P.R.C.  
Tel. 0086 (0) 21 61635996  
Fax 0086 (0) 21 61635992  
infoasia@motorpowerco.com